

HXDWH

# 产品目录——

## ST系列伺服电机

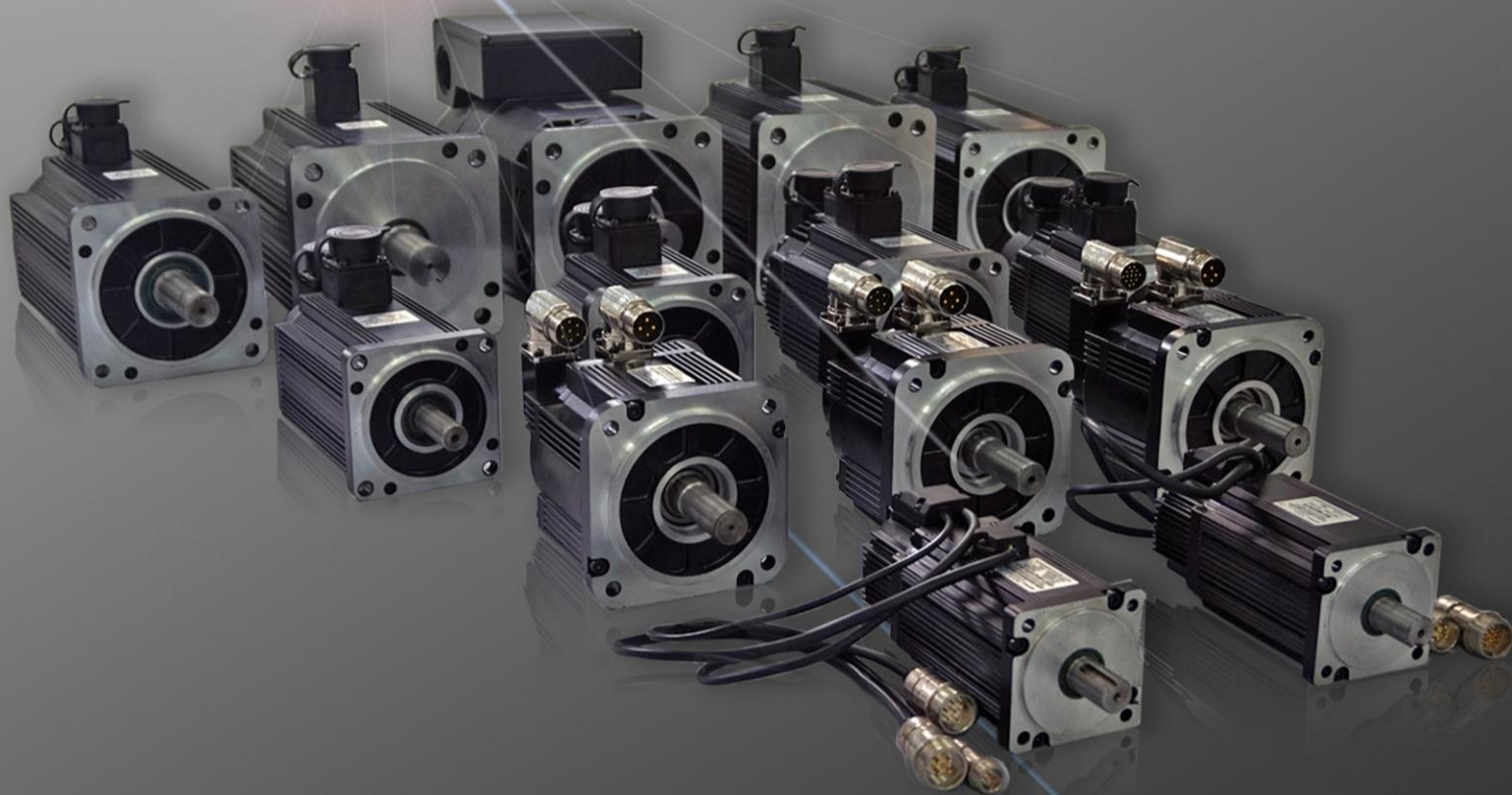

东莞市旭隆工控设备有限公司

HXDWH  
华大电机

黄清南

销售经理



13925507910  
xulonggk@yeah.net

广东省东莞市南城区新基育才路显福大厦802-806  
<http://www.xulonggk.cn>

# 华大电机

ISO9001 : 2015



# M02303202

## LB伺服电机

### LB SERVO MOTORS

机座号 (mm) : 110、130、150  
FRAME SIZE

额定转矩 (Nm) : 2.0~27  
RATED TORQUE

额定功率 (Kw) : 0.6~5.5  
RATED POWER

额定转速 (rpm) : 1500、2000、2500、3000  
RATED SPEED

最高转速 (rpm) : /  
MAXIMUM SPEED

极对数: 4  
POLES

转子惯量: 中惯量  
ROTOR INERTIA

反馈元件: 可选  
FEEDBACK

失电制动器: 可配  
POWER-OFF BRAKE

适配驱动器工作电压 (VAC) : 220  
MATCHED DRIVER WORKING VOLTAGE CODE

## LDD伺服电机

### LDD SERVO MOTORS

机座号 (mm) : 110、130  
FRAME SIZE

额定转矩 (Nm) : 4.2~17.8  
RATED TORQUE

额定功率 (Kw) : 0.65~3.1  
RATED POWER

额定转速 (rpm) : 1500、2000、3000  
RATED SPEED

最高转速 (rpm) : 2000、3000、4000  
MAXIMUM SPEED

极对数: 5  
POLES

转子惯量: 中惯量  
ROTOR INERTIA

反馈元件: 可选  
FEEDBACK

失电制动器: 可配  
POWER-OFF BRAKE

适配驱动器工作电压 (VAC) : 220  
MATCHED DRIVER WORKING VOLTAGE CODE

## LEE伺服电机

### LEE SERVO MOTORS

机座号 (mm) : 60、80  
FRAME SIZE

额定转矩 (Nm) : 0.32~4  
RATED TORQUE

额定功率 (Kw) : 0.1~1.3  
RATED POWER

额定转速 (rpm) : 3000  
RATED SPEED

最高转速 (rpm) : 6000  
MAXIMUM SPEED

极对数: 5  
POLES

转子惯量: 中惯量  
ROTOR INERTIA

反馈元件: 可选  
FEEDBACK

失电制动器: 可配  
POWER-OFF BRAKE

适配驱动器工作电压 (VAC) : 220  
MATCHED DRIVER WORKING VOLTAGE CODE

## HB伺服电机

### HB SERVO MOTORS

机座号 (mm) : 110、130、150  
FRAME SIZE

额定转矩 (Nm) : 2.0~27.0  
RATED TORQUE

额定功率 (Kw) : 0.6~5.5  
RATED POWER

额定转速 (rpm) : 1500、2000、2500、3000  
RATED SPEED

最高转速 (rpm) : /  
MAXIMUM SPEED

极对数: 4  
POLES

转子惯量: 中惯量  
ROTOR INERTIA

反馈元件: 可选  
FEEDBACK

失电制动器: 可配  
POWER-OFF BRAKE

适配驱动器工作电压 (VAC) : 380  
MATCHED DRIVER WORKING VOLTAGE CODE

## HBB伺服电机

### HBB SERVO MOTORS

机座号 (mm) : 150  
FRAME SIZE

额定转矩 (Nm) : 4.8~28.7  
RATED TORQUE

额定功率 (Kw) : 0.85~5.5  
RATED POWER

额定转速 (rpm) : 1500、2000  
RATED SPEED

最高转速 (rpm) : 3000  
MAXIMUM SPEED

极对数: 4  
POLES

转子惯量: 中惯量  
ROTOR INERTIA

反馈元件: 可选  
FEEDBACK

失电制动器: 可配  
POWER-OFF BRAKE

适配驱动器工作电压 (VAC) : 380  
MATCHED DRIVER WORKING VOLTAGE CODE

## HDD伺服电机

### HDD SERVO MOTORS

机座号 (mm) : 110、130、180  
FRAME SIZE

额定转矩 (Nm) : 4.2~55  
RATED TORQUE

额定功率 (Kw) : 0.65~8.6  
RATED POWER

额定转速 (rpm) : 1500、2000、3000  
RATED SPEED

最高转速 (rpm) : 2000、3000、4000  
MAXIMUM SPEED

极对数: 5  
POLES

转子惯量: 中惯量  
ROTOR INERTIA

反馈元件: 可选  
FEEDBACK

失电制动器: 可配  
POWER-OFF BRAKE

适配驱动器工作电压 (VAC) : 380  
MATCHED DRIVER WORKING VOLTAGE CODE

## STL伺服电机

### STL SERVO MOTORS

机座号 (mm) : 130  
FRAME SIZE

额定转矩 (Nm) : 9.8~15.8  
RATED TORQUE

额定功率 (Kw) : 3.0~5.0  
RATED POWER

额定转速 (rpm) : 3000  
RATED SPEED

最高转速 (rpm) : 6000  
MAXIMUM SPEED

极对数: 5  
POLES

转子惯量: 低惯量  
ROTOR INERTIA

反馈元件: 可选  
FEEDBACK

失电制动器: 可配  
POWER-OFF BRAKE

适配驱动器工作电压 (VAC) : 380  
MATCHED DRIVER WORKING VOLTAGE CODE

## HEE伺服电机

### HEE SERVO MOTORS

机座号 (mm) : 80  
FRAME SIZE

额定转矩 (Nm) : 1.3~4  
RATED TORQUE

额定功率 (Kw) : 0.4~1.3  
RATED POWER

额定转速 (rpm) : 3000  
RATED SPEED

最高转速 (rpm) : 6000  
MAXIMUM SPEED

极对数: 5  
POLES

转子惯量: 中惯量  
ROTOR INERTIA

反馈元件: 可选  
FEEDBACK

失电制动器: 可配  
POWER-OFF BRAKE

适配驱动器工作电压 (VAC) : 380  
MATCHED DRIVER WORKING VOLTAGE CODE

# 安装与连线

# INSTALLED & CONNECT

## 请您关注以下 ATTENTIONS

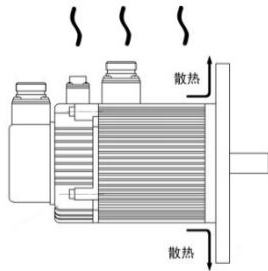

伺服电机为自冷式散热方式，安装时请选择足够大的安装板。伺服电机长期工作，机体本身会有一些温度，这是正常情况。

The servo motor operate with natural cooling, please mounting in enough size plate. It's normal that the motors generate some heat when in long-time working.

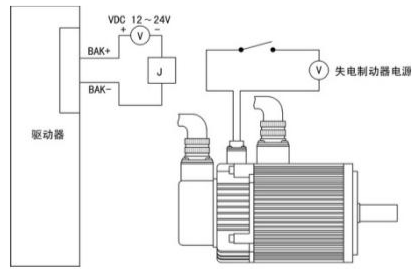

装配了失电制动器的伺服电机，其失电制动器的电源必须由驱动器控制开闭，否则会造成工作状态不佳。

The power-off brake in the some motor must be controled by drivers, if not, it will cause the motor default.

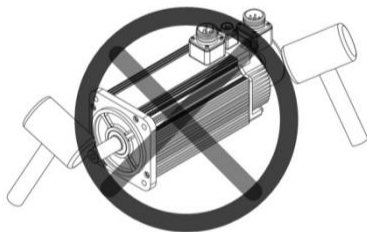

伺服电机内装精密反馈元件，严禁重力敲击电机轴伸端及后部。请注意电机轴伸端的最大径、轴向力的限值。

The motors have high-accuracy feedback components inside, please don't hit the shaft end and the rear. Pay attention to the limits of the maximum diameter and axial force about the shaft side.

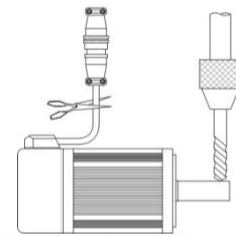

严禁随意更改、拆装及加工电机部件。请您将需求告之我们，我们来为您服务。

Don't change /assemble and process the parts of te motor arbitrarily. Please tell us your requirements ,we will at your service.

## 电机电连接器 MOTOR CONNECTOR

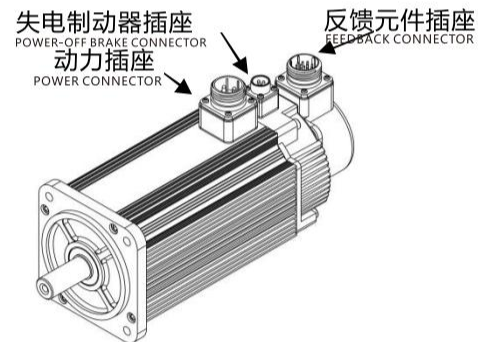
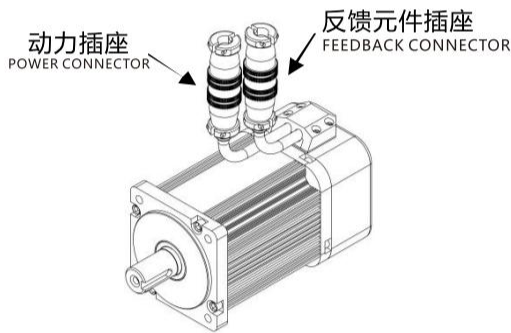

## 转矩转速曲线示意图 TORQUE & SPEED GRAPH

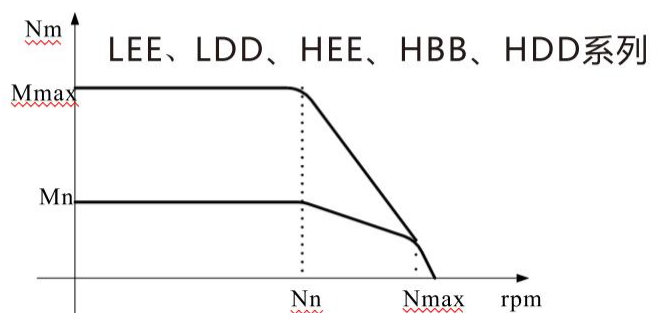
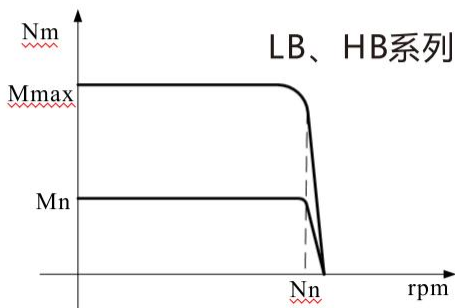

ST系列伺服电机的 $M_{max}=3M_n$ ； $M_{max}$ 输出状态为短时工作。使用时请查询配置的驱动器输出容量。

ST servo motor series  $m_{max}=3m_n$ .  $m_{max}$  output state is in short time operation. please refer to output capacity of configured driver while using

# 安装与连线

# INSTALLED & CONNECT

动力插座 (4P插座) : 60、80、110、130、150、180机座号  
POWER SOCKET (4PIN)

绕组引线	U	V	W	⊕
插头编号	2	3	4	1



反馈元件插座: 省线增量式编码器 (代码F1, 9P插座/插头)  
ENCODER SOCKET

信号	+5V	0V	A+	A-	B+	B-	Z+	Z-	⊕
插头编号	2	3	4	7	5	8	6	9	1

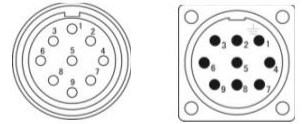

反馈元件插座: 非省线式增量编码器 (代码F、F5, 15 P, DB插座/插头)  
ENCODER SOCKET

信号	+5V	0V	A+	A-	B+	B-	Z+	Z-	U+	U-	V+	V-	W+	W-	⊕
插头编号	2	3	4	7	5	8	6	9	10	13	11	14	12	15	1

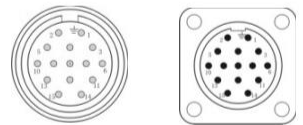

反馈元件插座: TAMAGAWA绝对式多圈编码器 (代码M、M1, 7P插座/插头)  
ENCODER SOCKET

信号	+5V	0V	SD+	SD-	E+	E-	⊕
插头编号	7	5	6	4	3	2	1

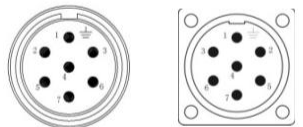

失电制动器插座 (2 P、3P) : 60、80、110、130、150、180机座号  
ELECTRIC LOSS BRAKE SOCKET

机座号	60	80	110	130	150	180
工作电压	24VDC	24VDC	24VDC	24VDC	100VDC	100VDC
制动转矩	≥1.3NM	≥2.5NM	≥8Nm	≥12Nm	≥30Nm	≥30Nm
工作电流	≤0.6A					
插座编号	1			2		
备注	电源接入无极性要求 150、180机座号亦可配DC24V失电制动器					

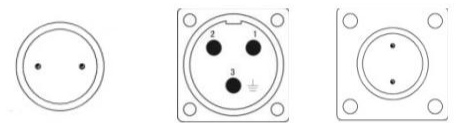

编码器代码:

**F:** 增量复合式光电编码器 (2500C/T)    **F1:** 省线增量复合光电编码器 (2500C/T)  
INCREMENTAL ENCODER (2500C/T)

**F5:** 增量复合式光电编码器 (5000C/T)  
INCREMENTAL ENCODER (5000C/T)

**M:** TAMAGAWA 绝对值串口协议光电编码器 (17bit/33bit)  
TAMAGAWA ABSOLUTE ENCODER (17bit/33bit)

**M1:** TAMAGAWA 绝对值串口协议光电编码器 (23bit/39bit)  
TAMAGAWA ABSOLUTE ENCODER (23bit/39bit)

**C:** 磁编码器  
MAGNETIC ENCODER

## 特点 FEATURES

机座 (mm) : 110、130、180  
FRAME SIZE

额定转速(rpm): 1500、2000、3000  
RATED SPEED

失电制动器: 选配  
ELECTRIC LOSS BRAKE

绝缘等级: F  
INSULATION GRADE

安装方式: 法兰盘  
INSTALLATION METHOD

环境温度: 0~55°C  
ENVIRONMENT TEMPERATURE

额定转矩 (Nm) : 4.2~55  
RATED TORQUE

最高转速 (rpm) : 2000、3000、4000  
MAXIMUM SPEED

额定功率(Kw): 0.65~8.6  
RATED POWER

极对数: 5  
POLES

防护等级: : 密封自冷式IP67  
PROTECTION CLASS

适配驱动器工作电压 (VAC) : 380  
MATCHED DRIVER

环境湿度: < 90% (无结露)  
ENVIRONMENT HUMIDITY

## HDD系列伺服电机命名规则 HDD PRODUCTS CODE SPECIFICATION

110	ST	-	M	042	15	30	H	M1	D	D	Z	/C
(1)	(2)		(3)	(4)	(5)	(6)	(7)	(8)	(9)	(10)	(11)	(12)

(1) 机座号  
FRAME SIZE

(4) 额定转矩: 三位数 × 0.1Nm  
RATED TORQUE: THE THREE-DIGIT NUMBER×0.1NM

(7) 驱动器工作电压 (VAC) : 380  
DRIVER WORKING VOLTAGE CODE

(10) 具有最高转速特性  
MAXIMUM SPEED FEATURES

(2) 交流永磁同步伺服电机  
AC PERMANENT MAGNET

(5) 额定转速: 二位数×100rpm  
RATED SPEED: THE DOUBLE-DIGITAL NUMBER×100RPM

(8) 编码器代码  
ENCODER CODE

(11) 安装了失电制动器  
WITH THE POWER-OFF BRAKE

(3) 反馈元件类型  
FEEDBACK COMPONENTS TYPE

(6) 最高转速: 二位数×100rpm  
MAXIMUM SPEED: THE DOUBLE-DIGITAL NUMBER×100RPM

(9) 产品系列  
PRODUCT SERIES

(12) 轴伸端键槽代码, 无键无代码  
THE SHAFT END KEYWAY CODE, NO CODE MEANS NO KEY

HDD系列一览表  
HDD SERIES LIST

电机型号 MOTOR TYPE	主要参数 TECHNICAL PARAMETERS				
	额定转矩 RATED TORQUE	额定转速 RATED SPEED	最高转速 MAXIMUM SPEED	额定电流 RATED CURRENT	额定功率 RATED POWER
110ST-M0422030H <sub>DD</sub>	4.2 Nm	2000 rpm	3000 rpm	2.8 A	0.88 Kw
110ST-M0423040H <sub>DD</sub>	4.2 Nm	3000 rpm	4000 rpm	4.0 A	1.3 Kw
110ST-M0542030H <sub>DD</sub>	5.4 Nm	2000 rpm	3000 rpm	3.5 A	1.1 Kw
110ST-M0543040H <sub>DD</sub>	5.4 Nm	3000 rpm	4000 rpm	4.8 A	1.7 Kw
110ST-M0642030H <sub>DD</sub>	6.4 Nm	2000 rpm	3000 rpm	4.0 A	1.3 Kw
110ST-M0642040H <sub>DD</sub>	6.4 Nm	2000 rpm	4000 rpm	5.7 A	2.0 Kw
110ST-M0752030H <sub>DD</sub>	7.5 Nm	2000 rpm	3000 rpm	4.8 A	1.6 Kw
130ST-M0421530H <sub>DD</sub>	4.2 Nm	1500 rpm	3000 rpm	2.7 A	0.65 Kw
130ST-M0423040H <sub>DD</sub>	4.2 Nm	3000 rpm	4000 rpm	3.5 A	1.3 Kw
130ST-M0541530H <sub>DD</sub>	5.4 Nm	1500 rpm	3000 rpm	3.6 A	0.85 Kw
130ST-M0543040H <sub>DD</sub>	5.4 Nm	3000 rpm	4000 rpm	5.0 A	1.7 Kw
130ST-M0641530H <sub>DD</sub>	6.4 Nm	1500 rpm	3000 rpm	4.2 A	1.0 Kw
130ST-M0643040H <sub>DD</sub>	6.4 Nm	3000 rpm	4000 rpm	5.8 A	2.0 Kw
130ST-M0751530H <sub>DD</sub>	7.5 Nm	1500 rpm	3000 rpm	4.8 A	1.2 Kw
130ST-M0753040H <sub>DD</sub>	7.5 Nm	3000 rpm	4000 rpm	6.6 A	2.4 Kw
130ST-M0841530H <sub>DD</sub>	8.4 Nm	1500 rpm	3000 rpm	5.8 A	1.3 Kw
130ST-M0842040H <sub>DD</sub>	8.4 Nm	2000 rpm	4000 rpm	7.2 A	1.8 Kw
130ST-M0961530H <sub>DD</sub>	9.6 Nm	1500 rpm	3000 rpm	6.0 A	1.5 Kw
130ST-M0962040H <sub>DD</sub>	9.6 Nm	2000 rpm	4000 rpm	9.0 A	2.0 Kw
130ST-M1151530H <sub>DD</sub>	11.5 Nm	1500 rpm	3000 rpm	7.0 A	1.8 Kw
130ST-M1152040H <sub>DD</sub>	11.5 Nm	2000 rpm	4000 rpm	11.0 A	2.4Kw
130ST-M1461530H <sub>DD</sub>	14.6 Nm	1500 rpm	3000 rpm	9.0 A	2.3 Kw
130ST-M1462040H <sub>DD</sub>	14.6 Nm	2000 rpm	4000 rpm	13.2 A	3.1 Kw
130ST-M1781520H <sub>DD</sub>	17.8 Nm	1500 rpm	2000 rpm	7.6 A	2.8 Kw
180ST-M1861530H <sub>DD</sub>	18.6Nm	1500 rpm	3000 rpm	11 A	2.9Kw
180ST-M1862040H <sub>DD</sub>	18.6Nm	2000 rpm	4000 rpm	14.2A	3.7Kw
180ST-M2301530H <sub>DD</sub>	23.0 Nm	1500 rpm	3000 rpm	13.3 A	3.6 Kw
180ST-M2302040H <sub>DD</sub>	23.0 Nm	2000 rpm	4000 rpm	18.5A	4.8 Kw
180ST-M2801530H <sub>DD</sub>	28.0 Nm	1500 rpm	3000 rpm	16.5 A	4.4 Kw
180ST-M2802040H <sub>DD</sub>	28.0 Nm	2000 rpm	4000 rpm	22 A	5.9 Kw
180ST-M3501530H <sub>DD</sub>	35.0 Nm	1500 rpm	3000 rpm	20.5 A	5.5 Kw
180ST-M4801530H <sub>DD</sub>	48.0 Nm	1500 rpm	3000 rpm	27.0 A	7.5 Kw
180ST-M5501530H <sub>DD</sub>	55.0 Nm	1500 rpm	3000 rpm	31.0 A	8.6 Kw

## ● 110 机座 (2000rpm/3000rpm)

FRAME

电机型号 MOTOR TYPE	110ST-M0422030H□DD	110ST-M0542030H□DD	110ST-M0642030H□DD	110ST-M0752030H□DD
额定功率 RATED POWER	0.88 Kw	1.1 Kw	1.3 Kw	1.6 Kw
额定转矩 RATED TORQUE	4.2 Nm	5.4 Nm	6.4 Nm	7.5 Nm
额定转速 RATED SPEED	2000 rpm	2000 rpm	2000 rpm	2000 rpm
最高转速 MAXIMUM SPEED	3000 rpm	3000 rpm	3000 rpm	3000 rpm
额定电流 RATED CURRENT	2.8 A	3.5 A	4.0 A	4.8 A
转子惯量 ROTOR INERTIA	0.787 Kg $m^2 \times 10^{-3}$ (0.851Kg $m^2 \times 10^{-3}$ )	0.916 Kg $m^2 \times 10^{-3}$ (0.98 Kg $m^2 \times 10^{-3}$ )	1.061 Kg $m^2 \times 10^{-3}$ (1.125 Kg $m^2 \times 10^{-3}$ )	1.238 Kg $m^2 \times 10^{-3}$ (1.302 Kg $m^2 \times 10^{-3}$ )
机械时间常数 MECHANICAL CONSTANT TIME	2.40ms	1.82 ms	1.60 ms	1.38 ms
最大转矩 MAX TORQUE	12.6 Nm	16.2 Nm	19.2 Nm	22.5 Nm

## ● 110 机座 (3000rpm/4000rpm)

FRAME

电机型号 MOTOR TYPE	110ST-M0423040H□DD	110ST-M0543040H□DD	110ST-M0642040H□DD
额定功率 RATED POWER	1.3 Kw	1.7 Kw	1.3 Kw
额定转矩 RATED TORQUE	4.2 Nm	5.4 Nm	6.4 Nm
额定转速 RATED SPEED	3000 rpm	3000 rpm	2000 rpm
最高转速 MAXIMUM SPEED	4000 rpm	4000 rpm	4000 rpm
额定电流 RATED CURRENT	4.0 A	4.8 A	5.7A
转子惯量 ROTOR INERTIA	0.787 Kg $m^2 \times 10^{-3}$ (0.851Kg $m^2 \times 10^{-3}$ )	0.916 Kg $m^2 \times 10^{-3}$ (0.98 Kg $m^2 \times 10^{-3}$ )	1.061 Kg $m^2 \times 10^{-3}$ (1.125 Kg $m^2 \times 10^{-3}$ )
机械时间常数 MECHANICAL CONSTANT TIME	2.14ms	1.80 ms	1.74 ms
最大转矩 MAX TORQUE	12.6 Nm	16.2 Nm	19.2 Nm

括号内为带失电制动器的转子惯量。

Rotor moment of inertia with power-off brake in brackets.

□编码器代码

Encoder code

最大径、轴向力：

Max diameter/axial force

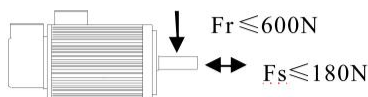

● 安装尺寸

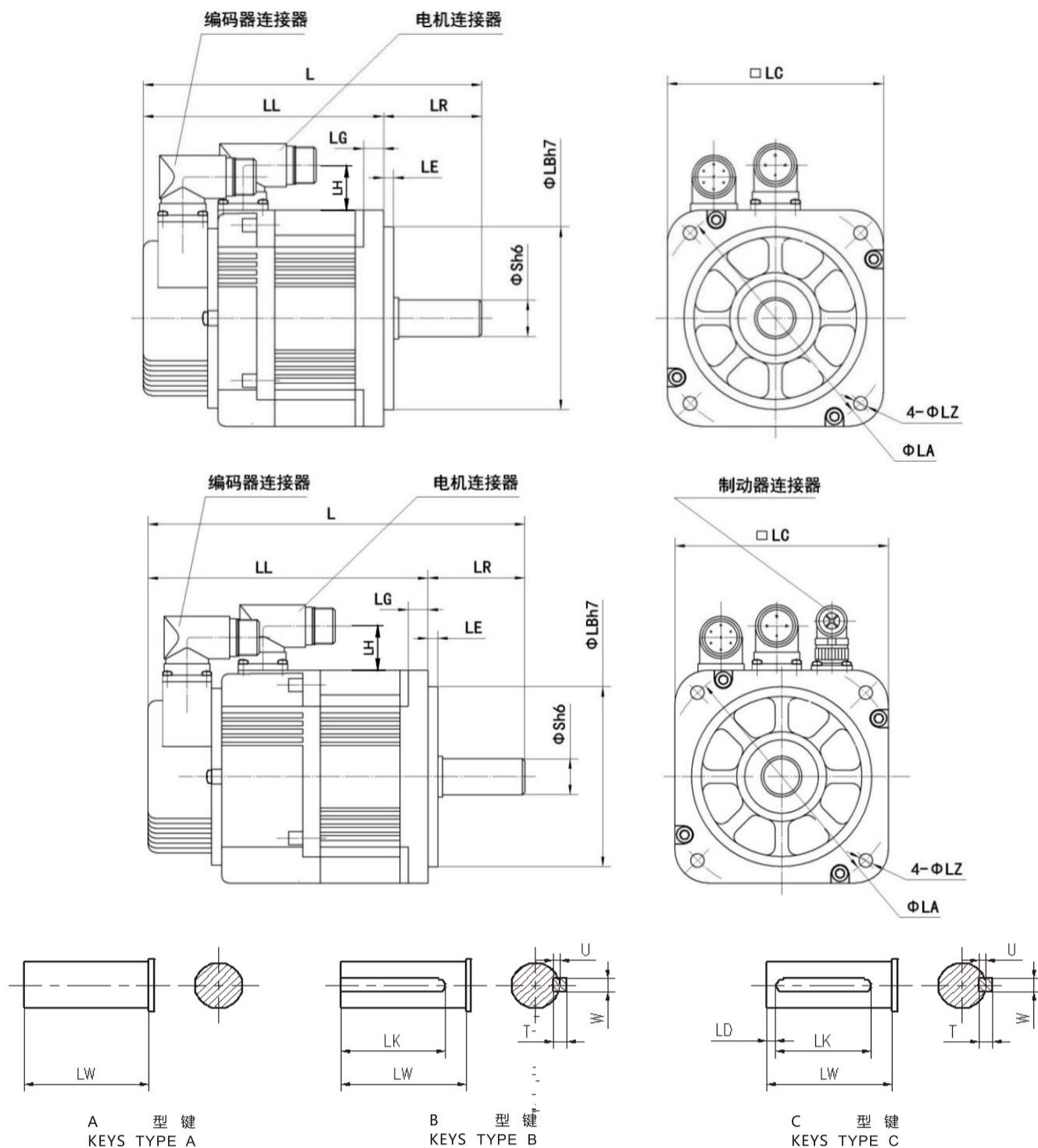

型号	L	LL	LR	LE	LG	LC	LA	LZ	$\Phi S$	LB	T	U	W	LK	LW	LD	LH
110ST-M0422030H□DD 110ST-M0423040H□DD	209 (245)	153 (189)	56	5	12	110	130	9	$19^{0}_{-0.013}$	$95^{0}_{-0.04}$	6	3.5	6	40	48	3	45
110ST-M0542030H□DD 110ST-M0543040H□DD	219 (255)	163 (199)	56	5	12	110	130	9	$19^{0}_{-0.013}$	$95^{0}_{-0.04}$	6	3.5	6	40	48	3	45
110ST-M0642030H□DD 110ST-M0642040H□DD	229 (265)	173 (209)	56	5	12	110	130	9	$19^{0}_{-0.013}$	$95^{0}_{-0.04}$	6	3.5	6	40	48	3	45
110ST-M0752030H□DD	240 (276)	184 (220)	56	5	12	110	130	9	$19^{0}_{-0.013}$	$95^{0}_{-0.04}$	6	3.5	6	40	48	3	45

注：括号内的数值为带失电制动器的电机长度。  
Attention: Rotor moment of inertia with power-off brake in brackets.

## ● 130 机座 (1500rpm/3000rpm)

FRAME

电机型号 MOTOR TYPE	130ST-M1151530H□DD	130ST-M1461530H□DD
额定功率 RATED POWER	1.8 Kw	2.3 Kw
额定转矩 RATED TORQUE	11.5 Nm	14.6 Nm
额定转速 RATED SPEED	1500 rpm	1500 rpm
最高转速 MAXIMUM SPEED	3000 rpm	3000 rpm
额定电流 RATED CURRENT	7.0 A	9.0 A
转子惯量 ROTOR INERTIA	3.015 Kg $m^2 \times 10^{-3}$ (3.182 Kg $m^2 \times 10^{-3}$ )	4.070 Kg $m^2 \times 10^{-3}$ (4.237 Kg $m^2 \times 10^{-3}$ )
机械时间常数 MECHANICAL CONSTANT TIME	2.224 ms	1.54 ms
最大转矩 MAX TORQUE	34.5 Nm	43.8 Nm

## ● 130 机座 (1500rpm/2000rpm)

FRAME

电机型号 MOTOR TYPE	130ST-M1781520H□DD
额定功率 RATED POWER	2.8 Kw
额定转矩 RATED TORQUE	17.8 Nm
额定转速 RATED SPEED	1500 rpm
最高转速 MAXIMUM SPEED	2000 rpm
额定电流 RATED CURRENT	19.0 A
转子惯量 ROTOR INERTIA	4.548 Kg $m^2 \times 10^{-3}$ (4.715 Kg $m^2 \times 10^{-3}$ )
机械时间常数 MECHANICAL CONSTANT TIME	1.454ms
最大转矩 MAX TORQUE	53.4 Nm

括号内为带失电制动器的转子惯量。

Rotor moment of inertia with power-off brake in brackets.

□编码器代码

Encoder code

最大径、轴向力:

Max diameter/axial force

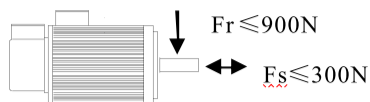

## ● 130 机座 (1500rpm/3000rpm)

FRAME

电机型号 MOTOR TYPE	130ST-M0421530H□DD	130ST-M0541530H□DD	130ST-M0641530H□DD
额定功率 RATED POWER	0.65 Kw	0.85 Kw	1.0 Kw
额定转矩 RATED TORQUE	4.2 Nm	5.4 Nm	6.4 Nm
额定转速 RATED SPEED	1500 rpm	1500 rpm	1500 rpm
最高转速 MAXIMUM SPEED	3000 rpm	3000 rpm	3000 rpm
额定电流 RATED CURRENT	2.7A	3.6 A	4.2 A
转子惯量 ROTOR INERTIA	1.163 Kg $m^2 \times 10^{-3}$ (1.33 Kg $m^2 \times 10^{-3}$ )	1.388 Kg $m^2 \times 10^{-3}$ (1.555 Kg $m^2 \times 10^{-3}$ )	1.604 Kg $m^2 \times 10^{-3}$ (1.771 Kg $m^2 \times 10^{-3}$ )
机械时间常数 MECHANICAL CONSTANT TIME	2.82ms	2.63 ms	2.11 ms
最大转矩 MAX TORQUE	12.6 Nm	16.2 Nm	19.2 Nm

## ● 130 机座 (1500rpm/3000rpm)

FRAME

电机型号 MOTOR TYPE	130ST-M0751530H□DD	130ST-M0841530H□DD	130ST-M0961530H□DD
额定功率 RATED POWER	1.2 Kw	1.3 Kw	1.5 Kw
额定转矩 RATED TORQUE	7.5 Nm	8.4 Nm	9.6 Nm
额定转速 RATED SPEED	1500 rpm	1500 rpm	1500 rpm
最高转速 MAXIMUM SPEED	3000 rpm	3000 rpm	3000 rpm
额定电流 RATED CURRENT	4.8 A	5.8 A	6.0 A
转子惯量 ROTOR INERTIA	1.857 Kg $m^2 \times 10^{-3}$ (2.024 Kg $m^2 \times 10^{-3}$ )	2.059 Kg $m^2 \times 10^{-3}$ (2.226 Kg $m^2 \times 10^{-3}$ )	2.369 Kg $m^2 \times 10^{-3}$ (2.536 Kg $m^2 \times 10^{-3}$ )
机械时间常数 MECHANICAL CONSTANT TIME	2.12 ms	2.21 ms	1.93 ms
最大转矩 MAX TORQUE	22.5 Nm	25.2 Nm	28.8 Nm

括号内为带失电制动器的转子惯量。

Rotor moment of inertia with power-off brake in brackets.

□编码器代码

Encoder code

最大径、轴向力：

Max diameter/axial force

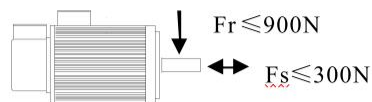

## ● 130 机座 (3000rpm/4000rpm)

FRAME

电机型号 MOTOR TYPE	130ST-M0423040H□DD	130ST-M0543040H□DD
额定功率 RATED POWER	1.3 Kw	1.7 Kw
额定转矩 RATED TORQUE	4.2 Nm	5.4 Nm
额定转速 RATED SPEED	3000 rpm	3000 rpm
最高转速 MAXIMUM SPEED	4000 rpm	4000 rpm
额定电流 RATED CURRENT	3.5 A	5.0 A
转子惯量 ROTOR INERTIA	1.163 Kg $m^2 \times 10^{-3}$ (1.33 Kg $m^2 \times 10^{-3}$ )	1.388 Kg $m^2 \times 10^{-3}$ (1.555 Kg $m^2 \times 10^{-3}$ )
机械时间常数 MECHANICAL CONSTANT TIME	2.74 ms	3.13 ms
最大转矩 MAX TORQUE	12.6 Nm	16.2 Nm

## ● 130 机座 (2000rpm/4000rpm、3000rpm/4000rpm)

FRAME

电机型号 MOTOR TYPE	130ST-M0643040H□DD	130ST-M0753040H□DD	130ST-M0842040H□DD
额定功率 RATED POWER	2.0 Kw	2.4 Kw	1.8 Kw
额定转矩 RATED TORQUE	6.4 Nm	7.5 Nm	8.4 Nm
额定转速 RATED SPEED	3000 rpm	3000 rpm	2000 rpm
最高转速 MAXIMUM SPEED	4000 rpm	4000 rpm	4000 rpm
额定电流 RATED CURRENT	5.8 A	6.6 A	7.2 A
转子惯量 ROTOR INERTIA	1.604 Kg $m^2 \times 10^{-3}$ (1.771 Kg $m^2 \times 10^{-3}$ )	1.857 Kg $m^2 \times 10^{-3}$ (2.024 Kg $m^2 \times 10^{-3}$ )	2.369 Kg $m^2 \times 10^{-3}$ (2.536 Kg $m^2 \times 10^{-3}$ )
机械时间常数 MECHANICAL CONSTANT TIME	2.544 ms	2.41 ms	2.19 ms
最大转矩 MAX TORQUE	19.2 Nm	22.5 Nm	25.2 Nm

括号内为带失电制动器的转子惯量。

Rotor moment of inertia with power-off brake in brackets.

□编码器代码

Encoder code

最大径、轴向力：

Max diameter/axial force

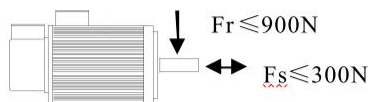

## ● 130 机座 (2000rpm/4000rpm)

FRAME

电机型号 MOTOR TYPE	130ST-M0962040H□DD	130ST-M1152040H□DD	130ST-M1462040H□DD
额定功率 RATED POWER	2.0 Kw	2.4 Kw	3.1 Kw
额定转矩 RATED TORQUE	9.6 Nm	11.5 Nm	14.6 Nm
额定转速 RATED SPEED	2000 rpm	2000 rpm	2000 rpm
最高转速 MAXIMUM SPEED	4000 rpm	4000 rpm	4000 rpm
额定电流 RATED CURRENT	9.0 A	11.0 A	13.2 A
转子惯量 ROTOR INERTIA	3.015 Kg $m^2 \times 10^{-3}$ (3.182 Kg $m^2 \times 10^{-3}$ )	4.070 Kg $m^2 \times 10^{-3}$ (4.237 Kg $m^2 \times 10^{-3}$ )	4.548 Kg $m^2 \times 10^{-3}$ (4.715 Kg $m^2 \times 10^{-3}$ )
机械时间常数 MECHANICAL CONSTANT TIME	2.11 ms	1.99 ms	1.65 ms
最大转矩 MAX TORQUE	28.8 Nm	34.5 Nm	43.8 Nm

括号内为带失电制动器的转子惯量。

Rotor moment of inertia with power-off brake in brackets.

□编码器代码

Encoder code

最大径、轴向力：

Max diameter/axial force

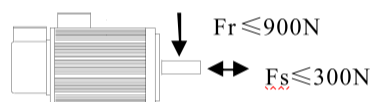

## ● 安装尺寸

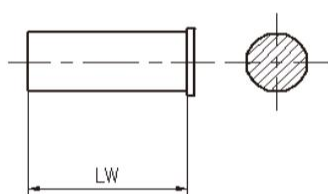
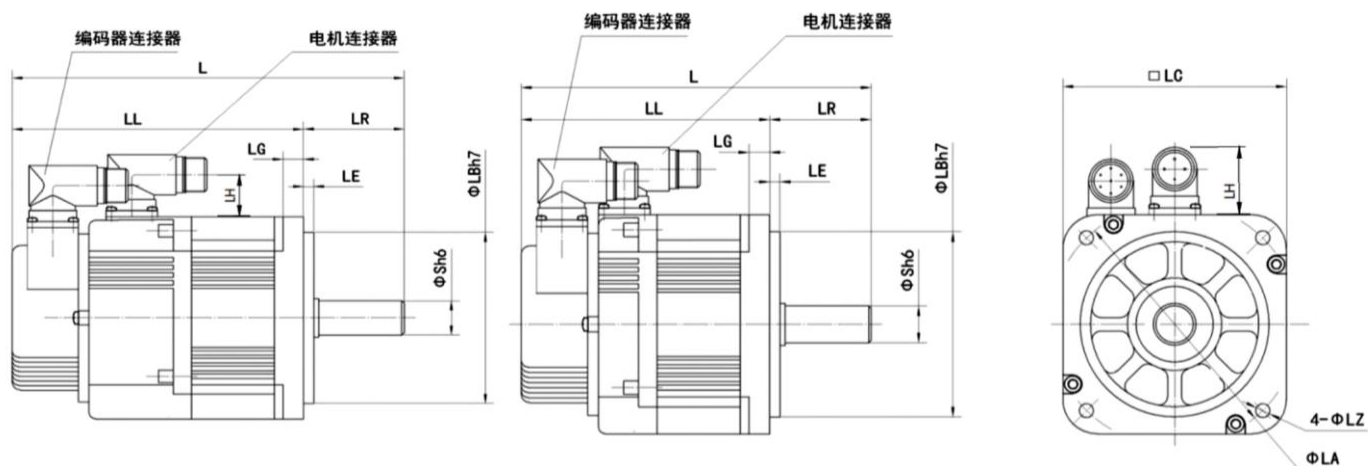

A 型键  
KEYS TYPE A

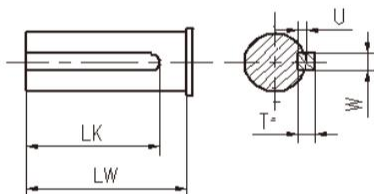

B 型键  
KEYS TYPE B

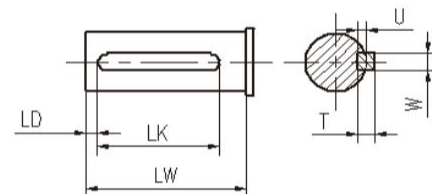

C 型键  
KEYS TYPE C

型号	L	LL	LR	LE	LG	LC	LA	LZ	$\phi S$	LB	T	U	W	LK	LW	LD	LH
130ST-M0421530H□DD 130ST-M0423040H□DD	198 (225)	139 (166)	59	6	12	130	145	8.5	$22_{-0.013}^0$	$110_{-0.04}^0$	6	3.5	6	40	50	5	45
130ST-M0541530H□DD 130ST-M0543040H□DD	204 (231)	145 (172)	59	6	12	130	145	8.5	$22_{-0.013}^0$	$110_{-0.04}^0$	6	3.5	6	40	50	5	45
130ST-M0641530H□DD 130ST-M0643040H□DD	211 (238)	152 (178)	59	6	12	130	145	8.5	$22_{-0.013}^0$	$110_{-0.04}^0$	6	3.5	6	40	50	5	45
130ST-M0751530H□DD 130ST-M0753040H□DD	218 (245)	159 (186)	59	6	12	130	145	8.5	$22_{-0.013}^0$	$110_{-0.04}^0$	6	3.5	6	40	50	5	45
130ST-M0841530H□DD 130ST-M0842040H□DD	224 (251)	165 (192)	59	6	12	130	145	8.5	$22_{-0.013}^0$	$110_{-0.04}^0$	6	3.5	6	40	50	5	45
130ST-M0961530H□DD 130ST-M0962040H□DD	232 (259)	173 (200)	59	6	12	130	145	8.5	$22_{-0.013}^0$	$110_{-0.04}^0$	6	3.5	6	40	50	5	45
130ST-M1151530H□DD 130ST-M1152040H□DD	251 (278)	192 (219)	59	6	12	130	145	8.5	$22_{-0.013}^0$	$110_{-0.04}^0$	6	3.5	6	40	50	5	45
130ST-M1461530H□DD 130ST-M1462040H□DD	283 (310)	224 (251)	59	6	12	130	145	8.5	$22_{-0.013}^0$	$110_{-0.04}^0$	6	3.5	6	40	50	5	45
130ST-M1781520H□DD	304 (331)	245 (272)	59	6	12	130	145	8.5	$22_{-0.013}^0$	$110_{-0.04}^0$	6	3.5	6	40	50	5	45

注：括号内的数值为带失电制动器的电机长度。

Attention: Rotor moment of inertia with power-off brake in brackets.

## ● 180机座 (1500rpm/3000rpm)

FRAME

电机型号 MOTOR TYPE	180ST-M1861530H□DD	180ST-M2301530H□DD	180ST-M2801530H□DD
额定功率 RATED POWER	2.9 Kw	3.6 Kw	4.4 Kw
额定转矩 RATED TORQUE	18.6 Nm	23.0 Nm	28.0 Nm
额定转速 RATED SPEED	1500 rpm	1500 rpm	1500 rpm
最高转速 MAXIMUM SPEED	3000 rpm	3000 rpm	3000 rpm
额定电流 RATED CURRENT	11 A	13.3 A	16.5 A
转子惯量 ROTOR INERTIA	5 Kg $m^2 \times 10^{-3}$ (5.6 Kg $m^2 \times 10^{-3}$ )	6.22 Kg $m^2 \times 10^{-3}$ (6.82 Kg $m^2 \times 10^{-3}$ )	6.8 Kg $m^2 \times 10^{-3}$ (7.4 Kg $m^2 \times 10^{-3}$ )
机械时间常数 MECHANICAL CONSTANT TIME	1.85ms	1.63 ms	1.18 ms
最大转矩 MAX TORQUE	55.8 Nm	69.0 Nm	84.0 Nm

## ● 180机座 (1500rpm/3000rpm)

FRAME

电机型号 MOTOR TYPE	180ST-M3501530H□DD	180ST-M4801530H□DD	180ST-M5501530H□DD
额定功率 RATED POWER	5.5 Kw	7.5 Kw	8.6 Kw
额定转矩 RATED TORQUE	35.0 Nm	48.0 Nm	55.0 Nm
额定转速 RATED SPEED	1500 rpm	1500 rpm	1500 rpm
最高转速 MAXIMUM SPEED	3000 rpm	3000 rpm	3000 rpm
额定电流 RATED CURRENT	20.5 A	27.0 A	31.0 A
转子惯量 ROTOR INERTIA	9.53 Kg $m^2 \times 10^{-3}$ (10.13 Kg $m^2 \times 10^{-3}$ )	12.58 Kg $m^2 \times 10^{-3}$ (13.18 Kg $m^2 \times 10^{-3}$ )	14.41 Kg $m^2 \times 10^{-3}$ (15.01 Kg $m^2 \times 10^{-3}$ )
机械时间常数 MECHANICAL CONSTANT TIME	1.28 ms	1.12 ms	1.19 ms
最大转矩 MAX TORQUE	105.0 Nm	144.0 Nm	165.0 Nm

括号内为带失电制动器的转子惯量。

Rotor moment of inertia with power-off brake in brackets.

□编码器代码

Encoder code

最大径、轴向力：

Max diameter/axial force

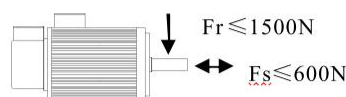

## ● 180机座 (2000rpm/4000rpm)

FRAME

电机型号 MOTOR TYPE	180ST-M1862040H□DD	180ST-M2302040H□DD	180ST-M2802040H□DD
额定功率 RATED POWER	3.7 Kw	4.8 Kw	5.9 Kw
额定转矩 RATED TORQUE	18.6 Nm	23.0 Nm	28.0 Nm
额定转速 RATED SPEED	2000 rpm	2000 rpm	2000 rpm
最高转速 MAXIMUM SPEED	4000 rpm	4000 rpm	4000 rpm
额定电流 RATED CURRENT	14.2 A	18.5 A	22 A
转子惯量 ROTOR INERTIA	5 Kg <sup>m</sup> ²×10 <sup>-3</sup> (5.6 Kg <sup>m</sup> ²×10 <sup>-3</sup> )	6.22 Kg <sup>m</sup> ²×10 <sup>-3</sup> (6.82 Kg <sup>m</sup> ²×10 <sup>-3</sup> )	6.8 Kg <sup>m</sup> ²×10 <sup>-3</sup> (7.4 Kg <sup>m</sup> ²×10 <sup>-3</sup> )
机械时间常数 MECHANICAL CONSTANT TIME	1.88ms	1.4 ms	1.32 ms
最大转矩 MAX TORQUE	55.8 Nm	69.0 Nm	84.0 Nm

括号内为带失电制动器的转子惯量。

Rotor moment of inertia with power-off brake in brackets.

□编码器代码

Encoder code

最大径、轴向力:

Max diameter/axial force

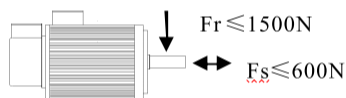

## ● 安装尺寸

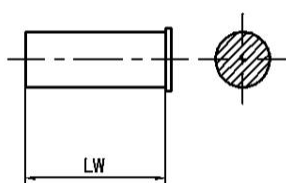
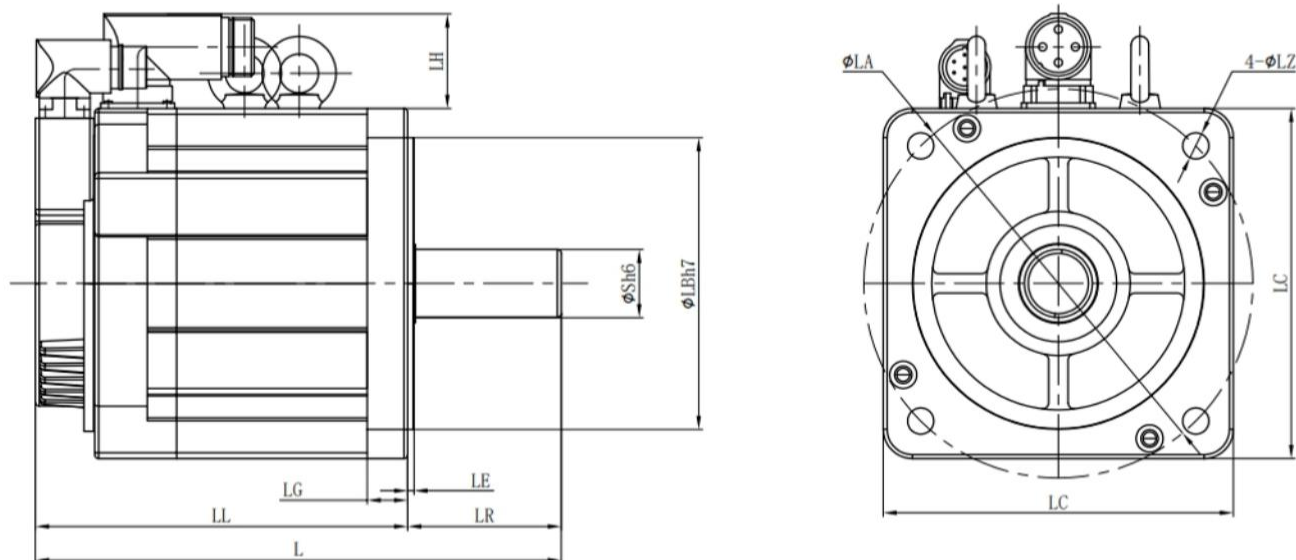

A 型 键  
KEYS TYPE A

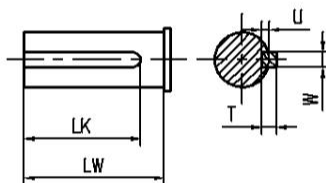

B 型 键  
KEYS TYPE B

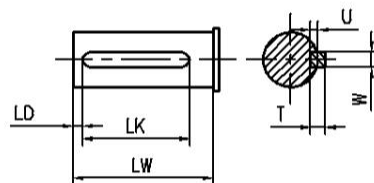

C 型 键  
KEYS TYPE C

型号	L	LL	LR	LE	LG	LC	LA	LZ	$\phi S$	LB	T	U	W	LK	LW	LD	LH
180ST-M1861530H□DD 180ST-M1862040H□DD	266 (316)	187 (237)	79	3.2	20.8	180	200	13.5	$35^{0}_{-0.013}$	$114.3^{0}_{-0.04}$	8	5	10	60	75	5	50
180ST-M2301530H□DD 180ST-M2302040H□DD	280 (330)	201 (251)	79	3.2	20.8	180	200	13.5	$35^{0}_{-0.013}$	$114.3^{0}_{-0.04}$	8	5	10	60	75	5	50
180ST-M2801530H□DD 180ST-M2802040H□DD	296 (346)	217 (267)	79	3.2	20.8	180	200	13.5	$35^{0}_{-0.013}$	$114.3^{0}_{-0.04}$	8	5	10	60	75	5	50
180ST-M3501530H□DD	317 (367)	238 (288)	79	3.2	20.8	180	200	13.5	$35^{0}_{-0.013}$	$114.3^{0}_{-0.04}$	8	5	10	60	75	5	50
180ST-M4801530H□DD	352 (402)	273 (323)	79	3.2	20.8	180	200	13.5	$35^{0}_{-0.013}$	$114.3^{0}_{-0.04}$	8	5	10	60	75	5	50
180ST-M5501530H□DD	372 (422)	293 (343)	79	3.2	20.8	180	200	13.5	$35^{0}_{-0.013}$	$114.3^{0}_{-0.04}$	8	5	10	60	75	5	50

注：括号内的数值为带失电制动器的电机长度。  
Attention: Rotor moment of inertia with power-off brake in brackets.

LB尺寸可选配 $150^{0}_{-0.04}$  大止口

武汉华大新型电机科技股份有限公司是一家专业研发、生产和销售控制电机的专业厂家。

华大电机公司位于武汉市江夏区藏龙岛科技园谭湖二路6号。公司拥有40亩办公生产用地，已完成一期工程并投入使用，建筑面积达14,000平方米。

生产厂房建筑面积12,000平方米，拥有高速冲床组成的定转子冲片生产线、数控车床数控磨床等组成的机加工生产线、多工位全自动电泳生产线、多工位定子嵌线生产线、电机成品检测线等200余台设备和检测仪器。



HXDWH

华大电机



定转子冲片生产线



全自动嵌线生产线



机加工生产线



电机总装生产线

由丝入微  
与您共进