

## DR系列—经久耐用，节省空间

DR SERIES—DURABLE AND SAVING SPACE

DR系列是D系列的有效拓展，  
这种直角型减速机适用于对减速机/电机安装空  
间要求非常节省的场合。

The DR series is an effective expansion of the D series  
This kind of right-angle reducer is suitable for situations where  
the installation space of reducer/motor is very economical.

### 技术参数\* TECHNICAL PARAMETERS

回程间隙 Return clearance	arcmin	2~9
速比 Speed ratio	i	3~100
额定输出力矩 Rated output torque	Nm	14~2000
使用温度°C Using temperature°C	°C	-10~90
噪音 The noise	dB(A)	61~74
工作效率 The work efficiency	%	95
工作寿命 The working life	h	20000

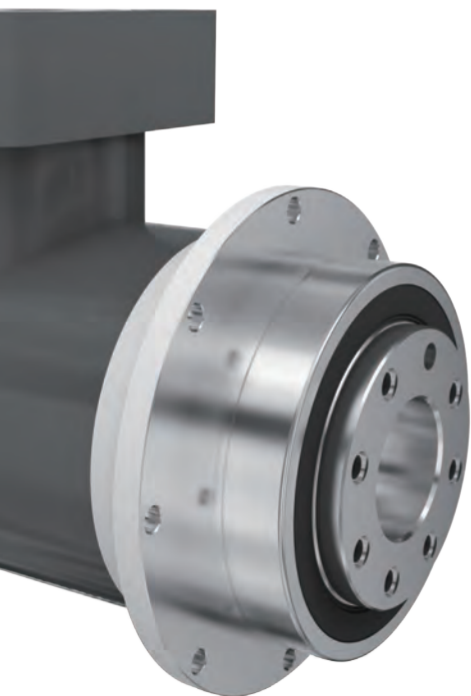

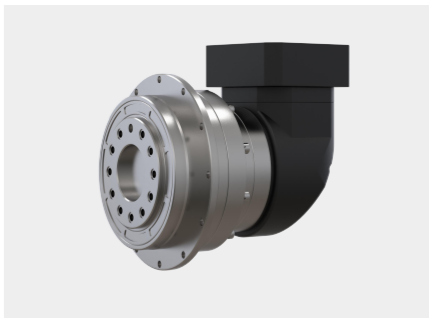
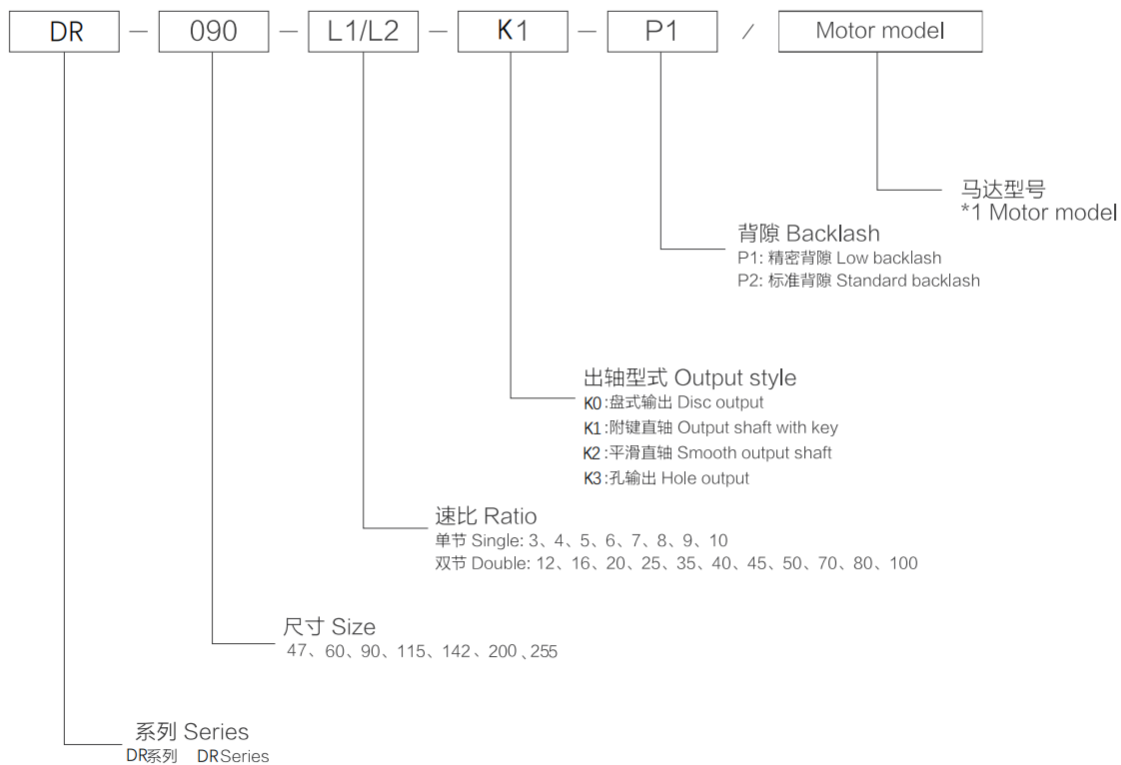

DR系列一经久耐用, 节省空间  
DR series-durable and saving space



锁紧环经动平衡分析, 确保连转中, 同心度和零滑差传递

The dynamic balance analysis of the locking ring ensures the concentricity and zero slip transfer in the continuous rotation

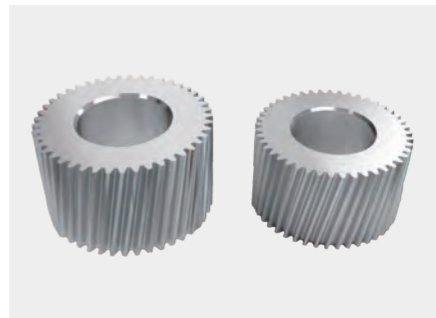

齿面宽, 参数做大, 实现高强度

The tooth surface is wide, the parameters are larger, and the high strength is achieved



太阳齿一体式设计, 确保同心度和扭转刚性

Integrated solar tooth design ensures concentricity and torsional rigidity

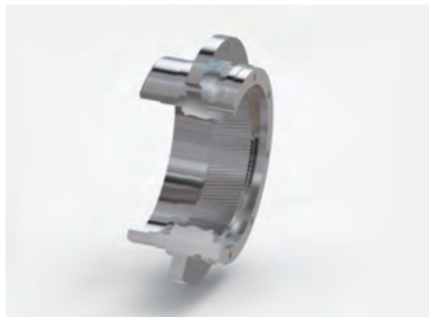

先进表面处理耐磨, 耐刮, 耐腐蚀

Advanced surface treatment wear-resistant, scratch-resistant, corrosion-resistant

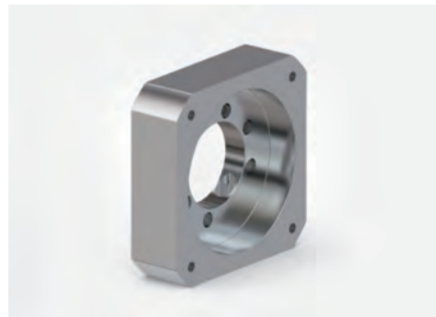

一体化连接板设计, 与各种伺服, 马达完美配合

Integrated connection board design, perfect coordination with various servo and motors

减速机性能资料 REDUCER PERFORMANCE DATA

DR047			单级/One-stage							双级/Two-stage								
速比 <sup>(1)</sup> Speed ratio	i		4	5	6	7	8	9	10	16	20	25	35	40	50	70	100	
额定输出力矩(n <sub>1N</sub> ) Rated output torque	T <sub>2N</sub>	Nm	19	22	20	19	17	14	14	19	19	22	19	17	22	19	14	
紧急制动力矩 Emergency braking torque (在减速机使用寿命内允许1000次) (1000 times during the working life of the reducer)	T <sub>2NOT</sub>	Nm	3倍额定输出力矩/3 Times rated output torque															
额定输入转速(T <sub>2n</sub> , 20°C环境温度) Rated input speed (T <sub>2n</sub> , 20 °C ambient temperature)	n <sub>1N</sub>	rpm	5000															
最大输入转速 Maximum input speed	n <sub>1max</sub>	rpm	10000															
空载力矩(nl=3000rpm, 20°C环境温度) No-load torque (nl=3000 RPM, 20°C ambient temperature)	T <sub>012</sub>	Nm	0.4	0.4	0.3	0.3	0.2	0.2	0.2	0.3	0.3	0.3	0.3	0.3	0.2	0.2	0.1	
回程间隙PS Backlash PS	j <sub>t</sub>	Arcmin	≤2							≤3								
回程间隙P0 Backlash P0	j <sub>t</sub>	Arcmin	≤4							≤5								
回程间隙P1 Backlash P1	j <sub>t</sub>	Arcmin	≤6							≤7								
回程间隙P2 Backlash P2	j <sub>t</sub>	Arcmin	≤8							≤9								
扭转刚度 Torsional stiffness	C <sub>121</sub>	Nm/Arcmin	3															
最大轴向力 <sup>(2)</sup> Maximum axial force	F <sub>2AMax</sub>	N	990															
最大倾侧力矩 Maximum bending torque	F <sub>2RMax</sub>	Nm	43															
工作效率 Work efficiency	η	%	95							92								
工作寿命 <sup>(3)</sup> Service life	L <sub>n</sub>	h	20000															
噪音(i=10和n1=3000rpm, 空载) Noise(i=10 and n1=3000rpm, no load)	L <sub>PA</sub>	DB(A)	≤61															
重量 Weight	m	Kg	1.1							1.4								
安装方向 Installation direction			任意方向/Any direction															
使用温度 <sup>(4)</sup> Operating temperature	°C		-10~90															
润滑方式 Lubrication method			终生润滑/Lifetime lubrication															
防护等级 Protection level			IP65															
转动惯量 Moment of inertia 按减速机输入直径(mm) Input diameter based on the reducer(mm)	8	J <sub>1</sub>	Kgcm <sup>2</sup>	0.06	0.05	0.05	0.04	0.03	0.03	0.03	0.03	0.03	0.03	0.03	0.03	0.02	0.02	0.02
	11	J <sub>1</sub>	Kgcm <sup>2</sup>	0.13	0.12	0.12	0.12	0.11	0.07	0.06	0.1	0.08	0.08	0.07	0.07	0.06	0.06	0.05
	14	J <sub>1</sub>	Kgcm <sup>2</sup>	0.16	0.15	0.14	0.13	0.12	0.09	0.08	0.12	0.11	0.1	0.1	0.09	0.09	0.07	0.06

1. 可选其他减速比  
2. 输出轴中心点  
3. 连续运转时, 使用寿命为10000h  
4. 对温度有特殊要求请联系

1. Optional other ratio  
2. Output shaft center point  
3. Service life of 10000h in continuous operation  
4. For special requirements on temperature, please contact

单级/One-stage

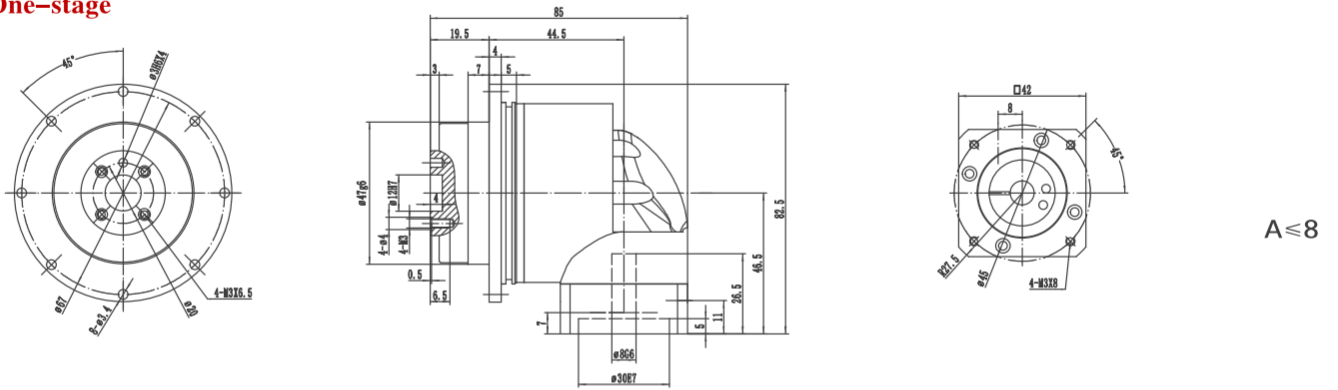

A ≤ 8

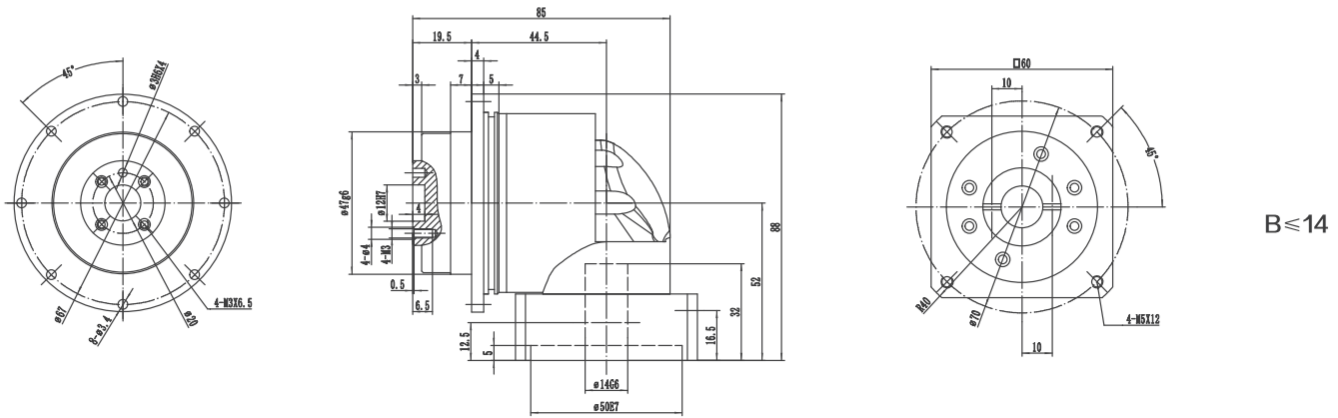

B ≤ 14

双级/Two-stage

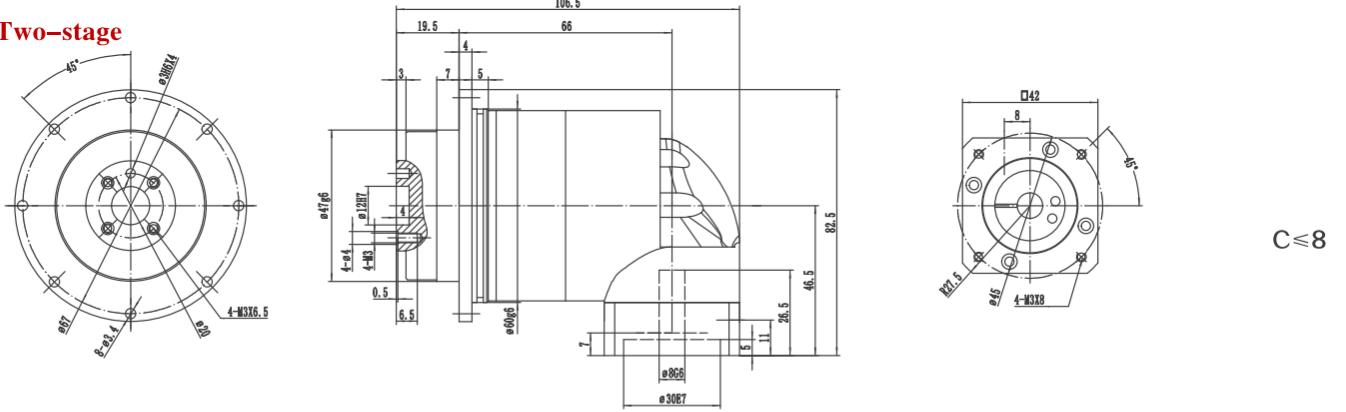

C ≤ 8

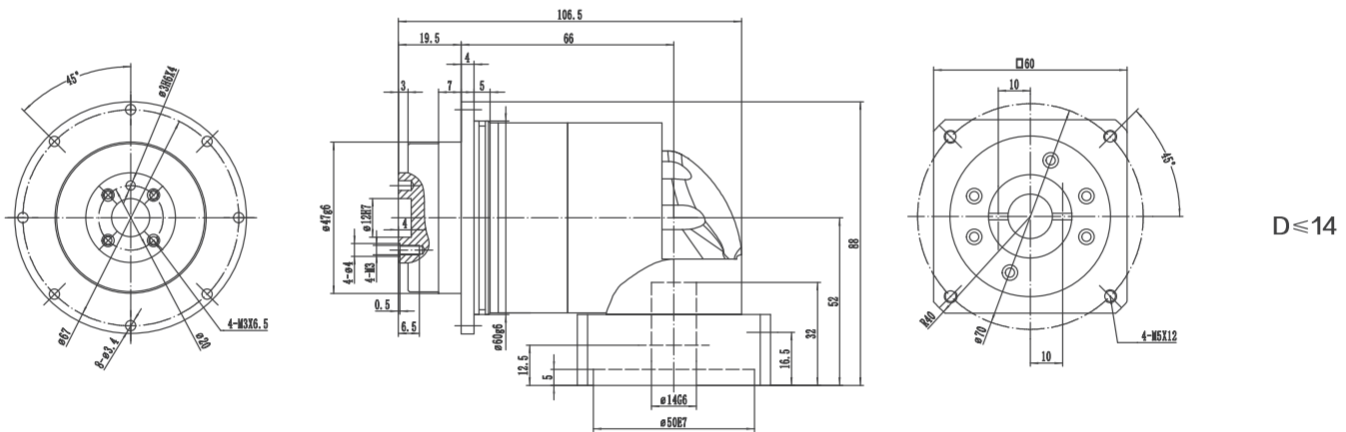

D ≤ 14

- (1) 请参照马达轴径尺寸
  - (2) 马达轴最长长度, 如有特殊的马达轴尺寸, 请联系
  - (3) 减速机输入端尺寸, 依马达的法兰面而定
- \*如无适合的尺寸, 请联系

- (1) Please refer to the motor shaft diameter
  - (2) Motor shaft length, for special motor shaft size, please contact
  - (3) Reducer input size, depending on the flange surface of the motor
- \*If no suitable size available, please contact

减速机性能资料 REDUCER PERFORMANCE DATA

DR064			单级/One-stage									双级/Two-stage							
速比 <sup>(1)</sup> Speed ratio	i		4	5	6	7	8	9	10	16	20	25	30	35	40	50	60	70	100
额定输出力矩( $n_{1N}$ ) Rated output torque	$T_{2N}$	Nm	50	60	55	50	45	40	40	45	40	60	55	50	50	50	55	50	40
紧急制动力矩 (在减速机使用寿命内允许1000次) (1000 times during the working life of the reducer)	$T_{2NOT}$	Nm	3倍额定输出力矩/3 Times rated output torque																
额定输入转速( $T_{2n}$ , 20°C环境温度) Rated input speed ( $T_{2n}$ , 20 °C ambient temperature)	$n_{1N}$	rpm	5000																
最大输入转速 Maximum input speed	$n_{1max}$	rpm	10000																
空载力矩( $n_1=3000rpm$ , 20°C环境温度) No-load torque ( $n_1=3000 RPM, 20^\circ C$ ambient temperature)	$T_{012}$	Nm	0.8	0.8	0.7	0.6	0.5	0.5	0.4	0.4	0.35	0.6	0.55	0.5	0.5	0.4	0.4	0.35	0.3
回程间隙PS Backlash PS	$j_t$	Arcmin	$\leq 2$									$\leq 3$							
回程间隙P0 Backlash P0	$j_t$	Arcmin	$\leq 4$									$\leq 5$							
回程间隙P1 Backlash P1	$j_t$	Arcmin	$\leq 6$									$\leq 7$							
回程间隙P2 Backlash P2	$j_t$	Arcmin	$\leq 8$									$\leq 9$							
扭转刚度 Torsional stiffness	$C_{121}$	Nm/Arcmin	4.5																
最大轴向力 <sup>(2)</sup> Maximum axial force	$F_{2AMax}$	N	1050																
最大倾侧力矩 Maximum bending torque	$F_{2RMax}$	Nm	125																
工作效率 Work efficiency	$\eta$	%	95									92							
工作寿命 <sup>(3)</sup> Service life	$L_h$	h	20000																
噪音 ( $i=10$ 和 $n_1=3000rpm$ , 空载) Noise ( $i=10$ and $n_1=3000rpm$ , no load)	$L_{PA}$	DB(A)	$\leq 63$																
重量 Weight	m	Kg	2.1									2.4							
安装方向 Installation direction			任意方向/Any direction																
使用温度 <sup>(4)</sup> Operating temperature	°C		-10~90																
润滑方式 Lubrication method			终生润滑/Lifetime lubrication																
防护等级 Protection level			IP65																
转动惯量 Moment of inertia 按减速机输入直径(mm) Input diameter based on the reducer(mm)	11	$J_1$	Kgcm <sup>2</sup>	0.2	0.2	0.15	0.13	0.12	0.1	0.1	0.1	0.08	0.1	0.09	0.08	0.08	0.08	0.08	0.08
	14	$J_1$	Kgcm <sup>2</sup>	0.25	0.25	0.22	0.18	0.17	0.15	0.14	0.14	0.12	0.17	0.17	0.16	0.16	0.16	0.16	0.15
	19	$J_1$	Kgcm <sup>2</sup>	0.6	0.055	0.55	0.52	0.5	0.5	0.48	0.45	0.42	0.18	0.16	0.15	0.15	0.15	0.15	0.14

1. 可选其他减速比  
2. 输出轴中心点  
3. 连续运转时, 使用寿命为10000h  
4. 对温度有特殊要求请联系

1. Optional other ratio  
2. Output shaft center point  
3. Service life of 10000h in continuous operation  
4. For special requirements on temperature, please contact

单级/One-stage

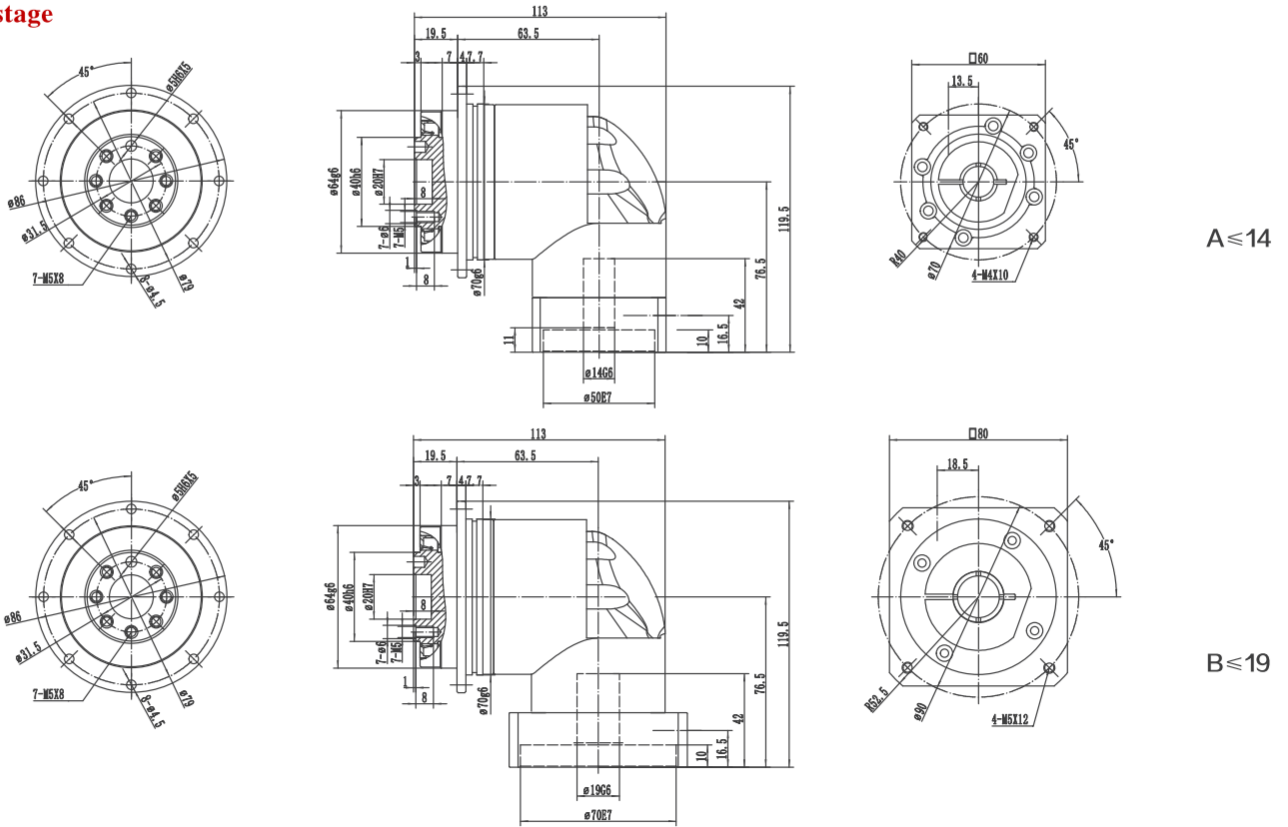

双级/Two-stage

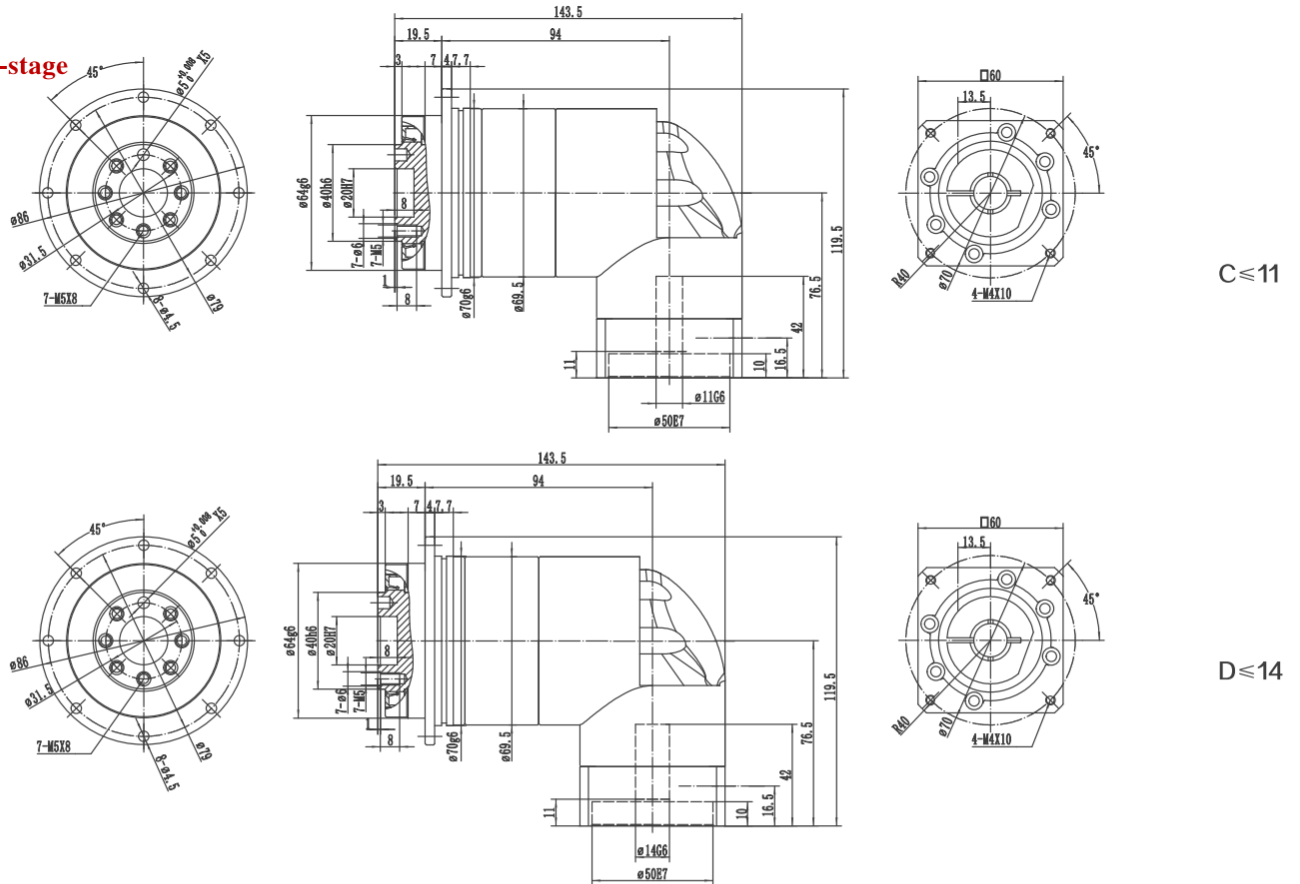

- (1) 请参照马达轴径尺寸
  - (2) 马达轴最长长度, 如有特殊的马达轴尺寸, 请联系
  - (3) 减速机输入端尺寸, 依马达的法兰面而定
- \*如无适合的尺寸, 请联系

- (1) Please refer to the motor shaft diameter
  - (2) Motor shaft length, for special motor shaft size, please contact
  - (3) Reducer input size, depending on the flange surface of the motor
- \*If no suitable size available, please contact

DR090			单级/One-stage									双级/Two-stage								
速比 <sup>(1)</sup> Speed ratio	i		4	5	6	7	8	9	10	16	20	16	20	25	35	40	50	70	100	
额定输出力矩( $n_{1N}$ ) Rated output torque	$T_{2N}$	Nm	140	160	140	140	120	100	100	120	100	140	140	160	140	140	160	120	100	
紧急制动力矩 (在减速机使用寿命内允许1000次) (1000 times during the working life of the reducer)	$T_{2NOT}$	Nm	3倍额定输出力矩/3 Times rated output torque																	
额定输入转速( $T_{2n}$ , 20°C环境温度) Rated input speed ( $T_{2n}$ , 20°C ambient temperature)	$n_{1N}$	rpm	3000																	
最大输入转速 Maximum input speed	$n_{1max}$	rpm	6000																	
空载力矩( $n_1=3000rpm$ , 20°C环境温度) No-load torque ( $n_1=3000RPM$ , 20°C ambient temperature)	$T_{012}$	Nm	1.7	1.6	1.5	1.4	1.1	0.8	0.7	0.7	0.7	0.8	0.7	0.6	0.5	0.5	0.4	0.3	0.3	
回程间隙PS Backlash PS	$j_t$	Arcmin	$\leq 2$									$\leq 3$								
回程间隙P0 Backlash P0	$j_t$	Arcmin	$\leq 4$									$\leq 5$								
回程间隙P1 Backlash P1	$j_t$	Arcmin	$\leq 6$									$\leq 7$								
回程间隙P2 Backlash P2	$j_t$	Arcmin	$\leq 8$									$\leq 9$								
扭转刚度 Torsional stiffness	$C_{121}$	Nm/Arcmin	14																	
最大轴向力 <sup>(2)</sup> Maximum axial force	$F_{2AMax}$	N	2850																	
最大倾侧力矩 Maximum bending torque	$F_{2RMax}$	Nm	235																	
工作效率 Work efficiency	$\eta$	%	95									92								
工作寿命 <sup>(3)</sup> Service life	$L_h$	h	20000																	
噪音( $i=10$ 和 $n_1=3000rpm$ , 空载) Noise( $i=10$ and $n_1=3000rpm$ , no load)	$L_{PA}$	DB(A)	$\leq 65$																	
重量 Weight	m	Kg	5.5									6								
安装方向 Installation direction			任意方向/Any direction																	
使用温度 <sup>(4)</sup> Operating temperature	°C		-10~90																	
润滑方式 Lubrication method			终生润滑/Lifetime lubrication																	
防护等级 Protection level			IP65																	
转动惯量 Moment of inertia 按减速机输入直径(mm) Input diameter based on the reducer(mm)	14	$J_1$	Kgcm <sup>2</sup>	1.3	1.2	1.1	0.9	0.8	0.7	0.6	0.6	0.5	0.23	0.21	0.2	0.18	0.18	0.18	0.16	0.16
	19	$J_1$	Kgcm <sup>2</sup>	2.1	2	2	1.8	1.7	1.5	1.5	1.4	1.3	0.7	0.7	0.7	0.7	0.7	0.6	0.5	0.5
	22	$J_1$	Kgcm <sup>2</sup>	2.4	2.3	2.3	2.2	2.2	2.1	2.1	2.1	2	0.8	0.07	0.7	0.7	0.7	0.65	0.8	0.6

1. 可选其他减速比  
2. 输出轴中心点  
3. 连续运转时, 使用寿命为10000h  
4. 对温度有特殊要求请联系

1. Optional other ratio  
2. Output shaft center point  
3. Service life of 10000h in continuous operation  
4. For special requirements on temperature, please contact

单级/One-stage

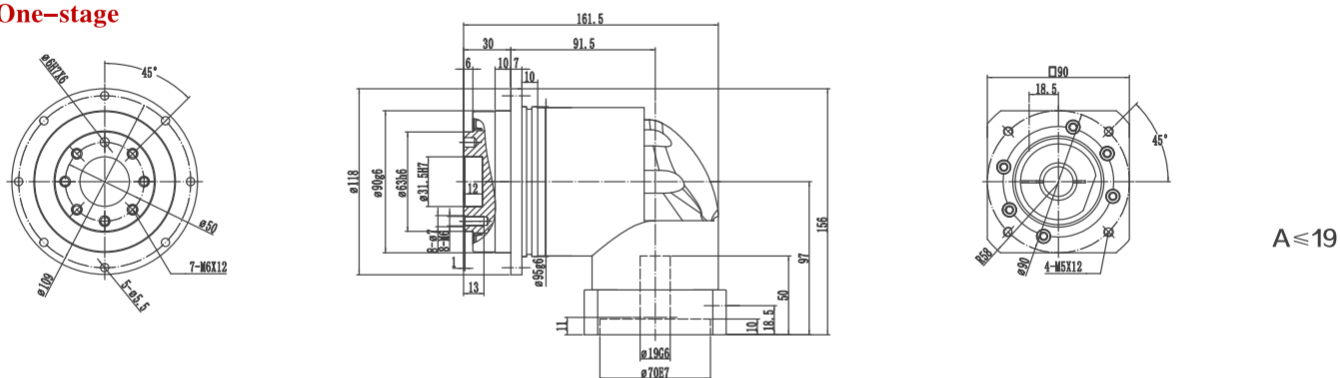

A ≤ 19

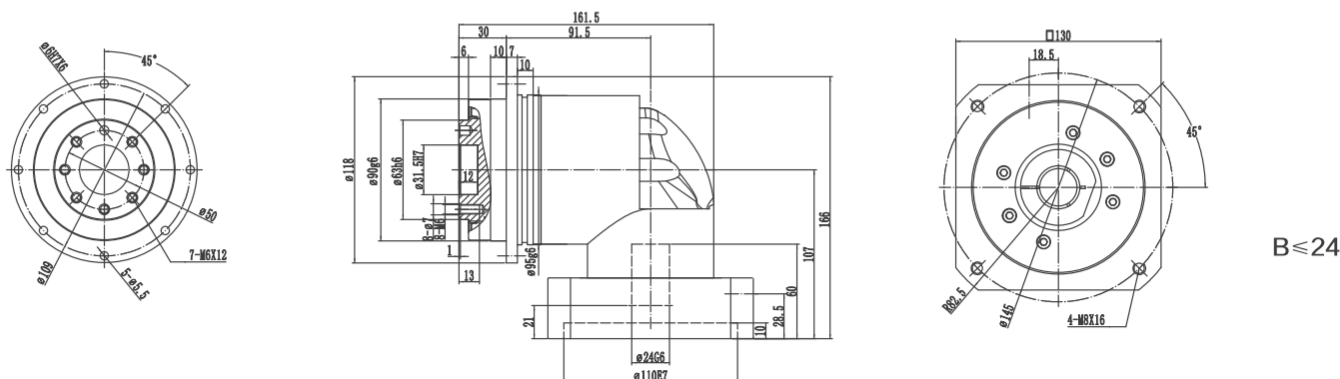

B ≤ 24

双级/Two-stage

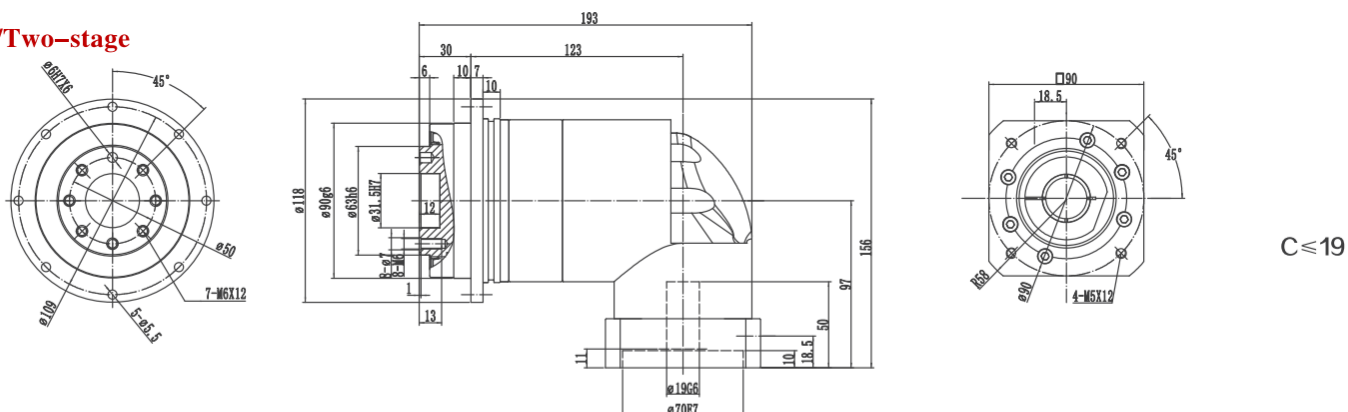

C ≤ 19

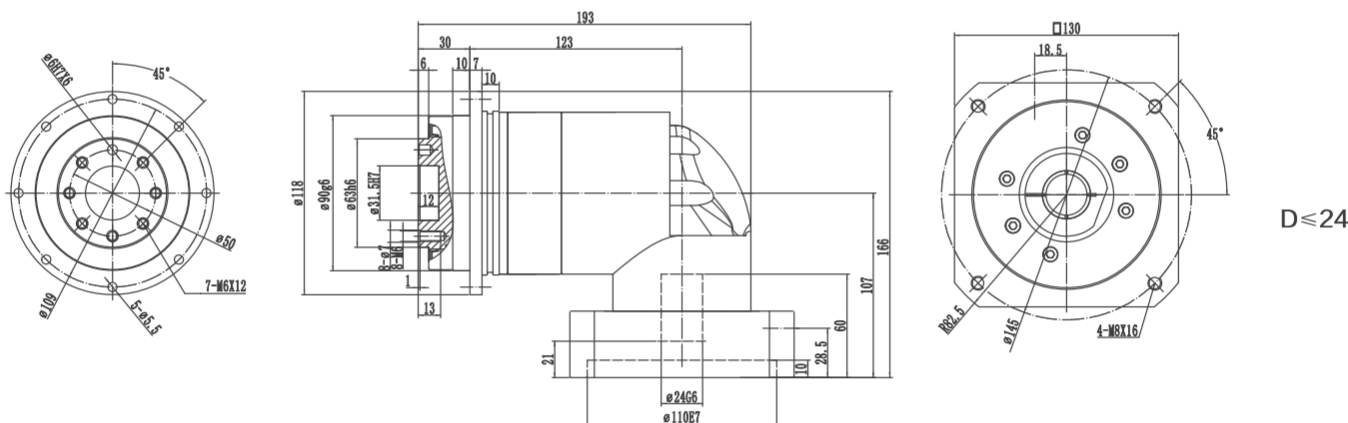

D ≤ 24

- (1) 请参照马达轴径尺寸
  - (2) 马达轴最长长度, 如有特殊的马达轴尺寸, 请联络
  - (3) 减速机输入端尺寸, 依马达的法兰面而定
- \*如无适合的尺寸, 请联系

- (1) Please refer to the motor shaft diameter
  - (2) Motor shaft length, for special motor shaft size, please contact
  - (3) Reducer input size, depending on the flange surface of the motor
- \*If no suitable size available, please contact

DR110			单级/One-stage									双级/Two-stage								
速比 <sup>(1)</sup> Speed ratio	i		4	5	6	7	8	9	10	16	20	16	20	25	35	40	50	70	100	
额定输出力矩( $n_{1N}$ ) Rated output torque	$T_{2N}$	Nm	290	330	300	300	260	230	230	260	230	290	290	330	300	330	330	300	230	
紧急制动力矩 (在减速机使用寿命内允许1000次) (1000 times during the working life of the reducer)	$T_{2NOT}$	Nm	3倍额定输出力矩/3 Times rated output torque																	
额定输入转速( $T_{2n}$ , 20°C环境温度) Rated input speed ( $T_{2n}$ , 20 °C ambient temperature)	$n_{1N}$	rpm	3000																	
最大输入转速 Maximum input speed	$n_{1max}$	rpm	6000																	
空载力矩( $n_l=3000rpm$ , 20°C环境温度) No-load torque ( $n_l=3000 RPM, 20^\circ C$ ambient temperature)	$T_{012}$	Nm	3	2.7	2.5	2	1.8	1.6	1.5	1.5	1.4	1.6	1.6	1.5	1.2	1	0.8	0.7	0.6	
回程间隙PS Backlash PS	$j_t$	Arcmin	$\leq 2$									$\leq 3$								
回程间隙P0 Backlash P0	$j_t$	Arcmin	$\leq 4$									$\leq 5$								
回程间隙P1 Backlash P1	$j_t$	Arcmin	$\leq 6$									$\leq 7$								
回程间隙P2 Backlash P2	$j_t$	Arcmin	$\leq 8$									$\leq 9$								
扭转刚度 Torsional stiffness	$C_{121}$	Nm/Arcmin	25																	
最大轴向力 <sup>(2)</sup> Maximum axial force	$F_{2AMax}$	N	2990																	
最大倾侧力矩 Maximum bending torque	$F_{2RMax}$	Nm	430																	
工作效率 Work efficiency	$\eta$	%	95									92								
工作寿命 <sup>(3)</sup> Service life	$L_h$	h	20000																	
噪音( $i=10$ 和 $n_l=3000rpm$ , 空载) Noise( $i=10$ and $n_l=3000rpm$ , no load)	$L_{PA}$	DB(A)	$\leq 68$																	
重量 Weight	m	Kg	8.8									10								
安装方向 Installation direction			任意方向/Any direction																	
使用温度 <sup>(4)</sup> Operating temperature	°C		-10~90																	
润滑方式 Lubrication method			终生润滑/Lifetime lubrication																	
防护等级 Protection level			IP65																	
转动惯量 Moment of inertia 按减速机输入直径(mm) Input diameter based on the reducer(mm)	19	$J_1$	Kgcm <sup>2</sup>	3	2.6	2.2	2	1.8	1.6	1.5	1.5	1.3	0.7	0.7	0.7	0.7	0.7	0.6	0.5	0.5
	22	$J_1$	Kgcm <sup>2</sup>	5.6	4.5	4	3.5	3	2.7	2.5	2.3	2.1	1.8	1.7	1.7	1.6	1.4	1.4	1.4	1.4
	24	$J_1$	Kgcm <sup>2</sup>	10.5	10	10	9.9	9.9	9.6	9.5	9	8.5	2.1	2.1	2	2	1.9	1.8	1.8	1.7

1. 可选其他减速比  
2. 输出轴中心点  
3. 连续运转时, 使用寿命为10000h  
4. 对温度有特殊要求请联系

1. Optional other ratio  
2. Output shaft center point  
3. Service life of 10000h in continuous operation  
4. For special requirements on temperature, please contact

单级/One-stage

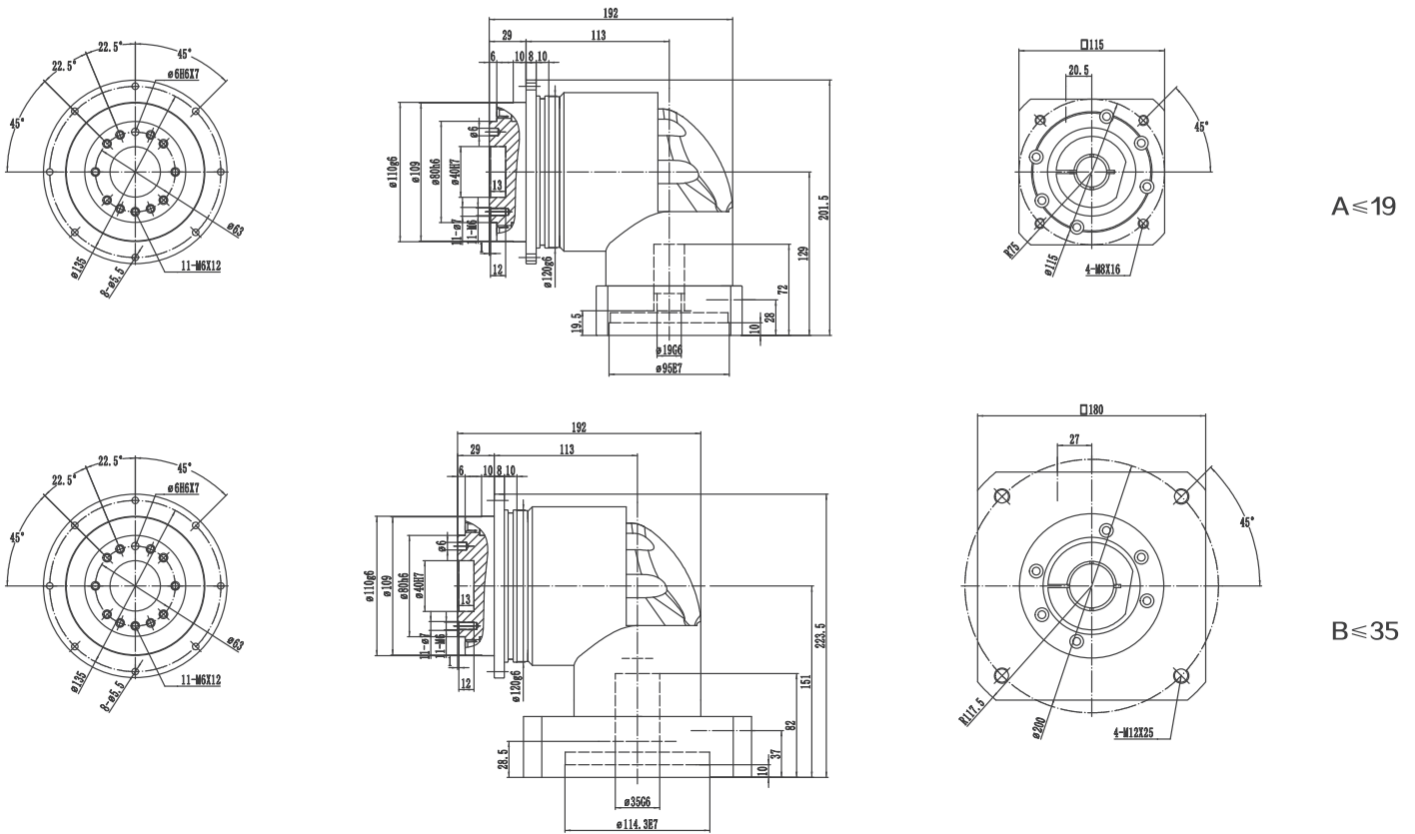

双级/Two-stage

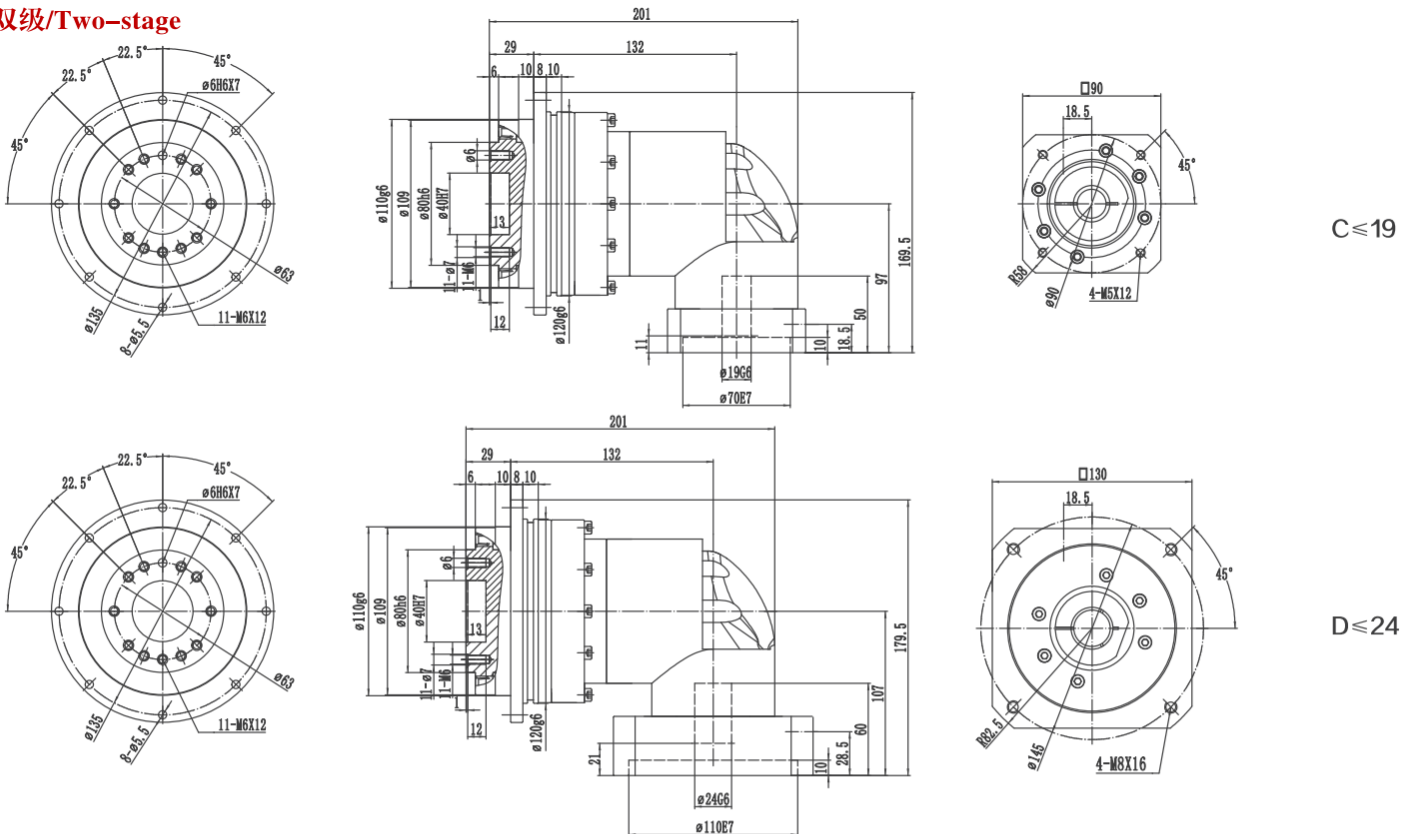

- (1) 请参照马达轴径尺寸
  - (2) 马达轴最长长度, 如有特殊的马达轴尺寸, 请联系
  - (3) 减速机输入端尺寸, 依马达的法兰面而定
- \*如无适合的尺寸, 请联系

- (1) Please refer to the motor shaft diameter
  - (2) Motor shaft length, for special motor shaft size, please contact
  - (3) Reducer input size, depending on the flange surface of the motor
- \*If no suitable size available, please contact

DR142			单级/One-stage									双级/Two-stage								
速比 <sup>(1)</sup> Speed ratio	i		4	5	6	7	8	9	10	16	20	16	20	25	35	40	50	70	100	
额定输出力矩( $n_{1N}$ ) Rated output torque	$T_{2N}$	Nm	542	650	550	550	500	450	450	500	450	542	542	650	550	542	650	550	450	
紧急制动力矩 Emergency braking torque (在减速机使用寿命内允许1000次) (1000 times during the working life of the reducer)	$T_{2NOT}$	Nm	3倍额定输出力矩/3 Times rated output torque																	
额定输入转速( $T_{2n}$ , 20°C环境温度) Rated input speed ( $T_{2n}$ , 20°C ambient temperature)	$n_{1N}$	rpm	3000																	
最大输入转速 Maximum input speed	$n_{1max}$	rpm	6000																	
空载力矩( $n_1=3000rpm$ , 20°C环境温度) No-load torque ( $n_1=3000RPM$ , 20°C ambient temperature)	$T_{012}$	Nm	6	4.7	4.5	3.5	2.5	2.5	2.5	2.4	2.2	2.8	2.6	2.2	2.0	1.9	1.8	1.6	1.5	
回程间隙PS Backlash PS	$j_t$	Arcmin	$\leq 2$									$\leq 3$								
回程间隙P0 Backlash P0	$j_t$	Arcmin	$\leq 4$									$\leq 5$								
回程间隙P1 Backlash P1	$j_t$	Arcmin	$\leq 6$									$\leq 7$								
回程间隙P2 Backlash P2	$j_t$	Arcmin	$\leq 8$									$\leq 9$								
扭转刚度 Torsional stiffness	$C_{121}$	Nm/Arcmin	50																	
最大轴向力 <sup>(2)</sup> Maximum axial force	$F_{2AMax}$	N	10590																	
最大倾侧力矩 Maximum bending torque	$F_{2RMax}$	Nm	1300																	
工作效率 Work efficiency	$\eta$	%	95									92								
工作寿命 <sup>(3)</sup> Service life	$L_h$	h	20000																	
噪音 ( $i=10$ 和 $n_1=3000rpm$ , 空载) Noise ( $i=10$ and $n_1=3000rpm$ , no load)	$L_{PA}$	DB(A)	$\leq 70$																	
重量 Weight	m	Kg	21									19								
安装方向 Installation direction			任意方向/Any direction																	
使用温度 <sup>(4)</sup> Operating temperature	°C		-10~90																	
润滑方式 Lubrication method			终生润滑/Lifetime lubrication																	
防护等级 Protection level			IP65																	
转动惯量 Moment of inertia 按减速机输入直径(mm) Input diameter based on the reducer(mm)	19	$J_1$	Kgcm <sup>2</sup>	8	8	7.2	7	6.5	5.8	5.5	5.2	5	2.2	2	1.7	1.7	1.6	1.4	1.4	1.4
	24	$J_1$	Kgcm <sup>2</sup>	12	11	10	10	9.5	9.5	9	9	8	3.2	3	2.9	2.7	2.5	2.3	2.2	2
	35	$J_1$	Kgcm <sup>2</sup>	25	24.5	24.1	23.5	23	22.5	22	22	20	12	11	10	10	9.5	9.5	9	9

1. 可选其他减速比  
2. 输出轴中心点  
3. 连续运转时, 使用寿命为10000h  
4. 对温度有特殊要求请 联系

1. Optional other ratio  
2. Output shaft center point  
3. Service life of 10000h in continuous operation  
4. For special requirements on temperature, please contact

减速机性能资料 REDUCER PERFORMANCE DATA

单级/One-stage

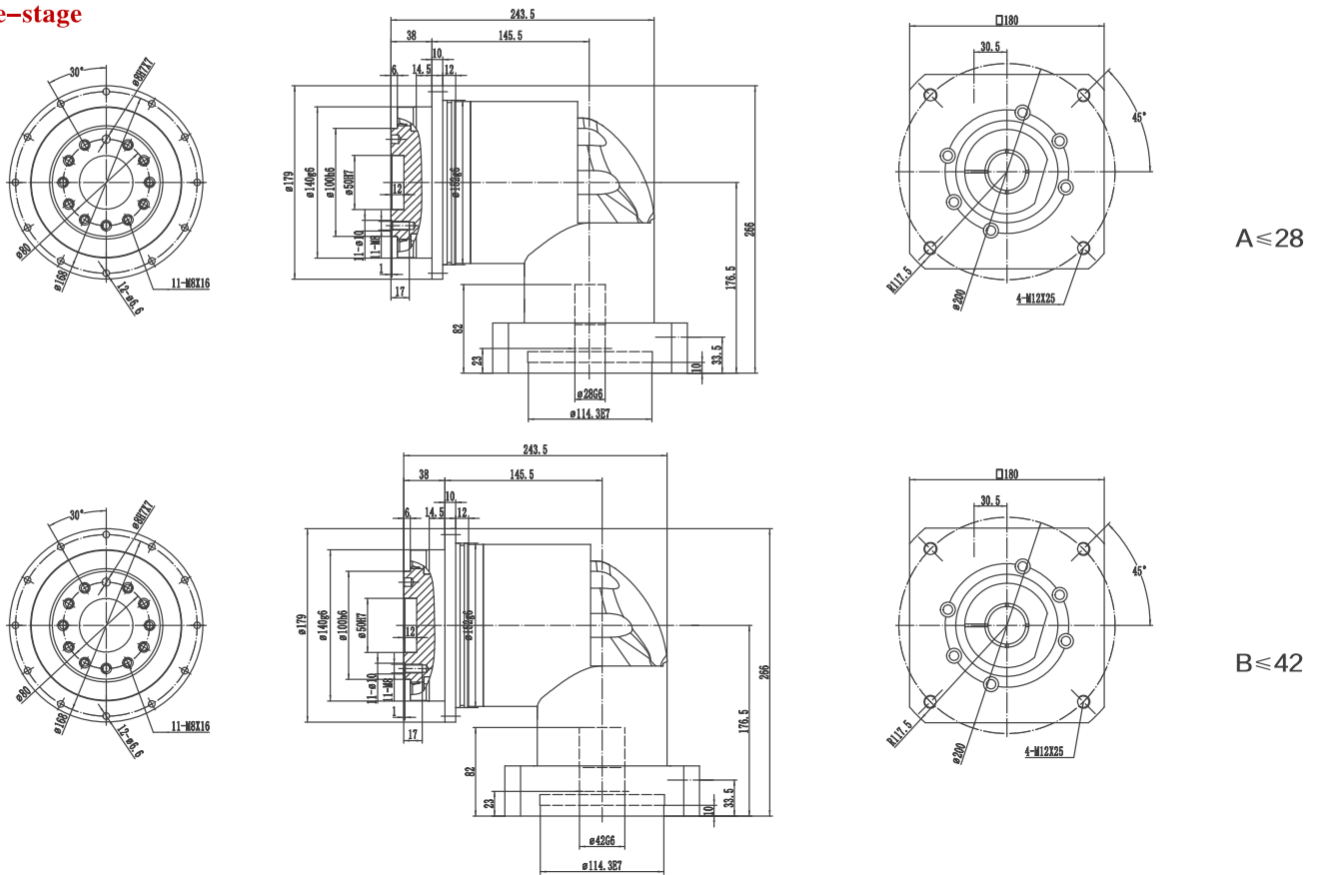

双级/Two-stage

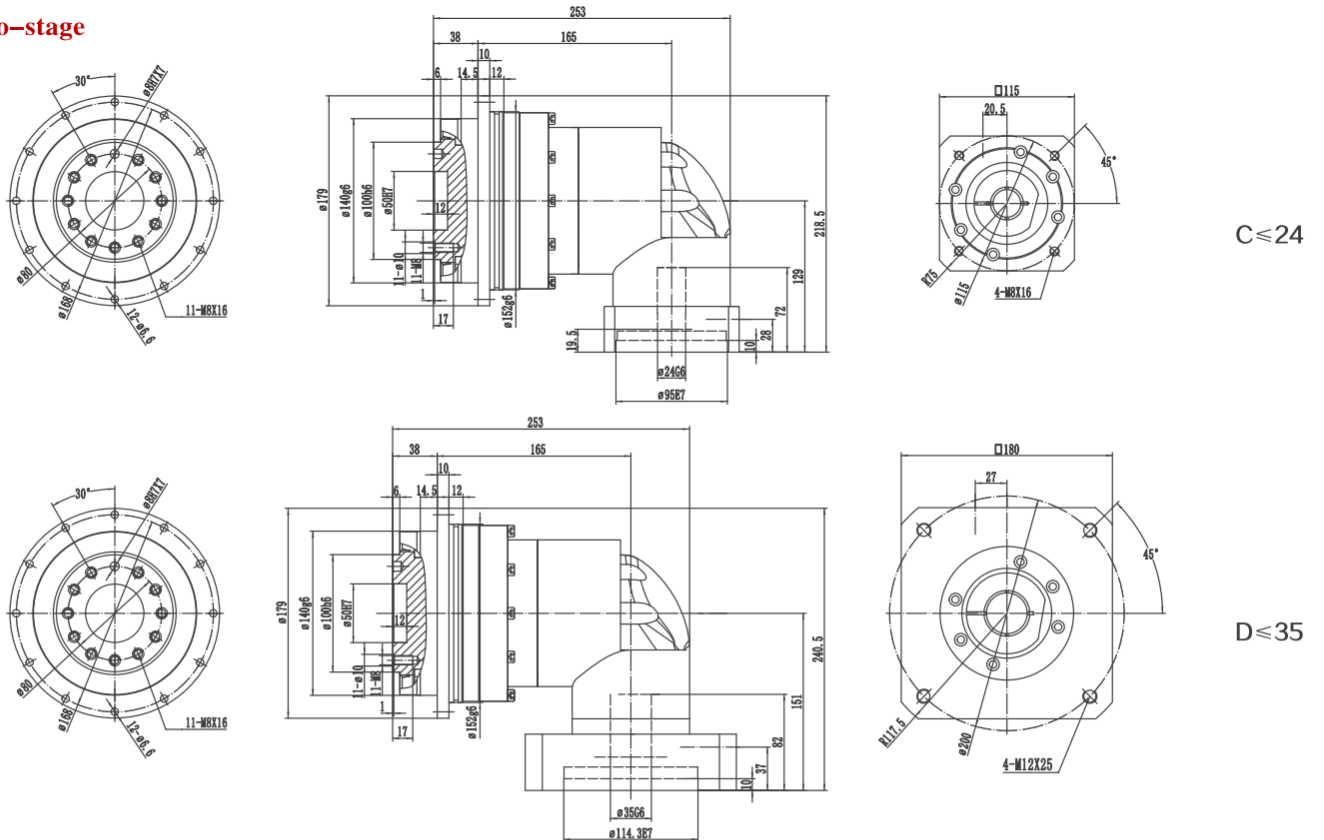

- (1) 请参照马达轴径尺寸
  - (2) 马达轴最长长度, 如有特殊的马达轴尺寸, 请联系
  - (3) 减速机输入端尺寸, 依马达的法兰面而定
- \*如无适合的尺寸, 请联系

- (1) Please refer to the motor shaft diameter
  - (2) Motor shaft length, for special motor shaft size, please contact
  - (3) Reducer input size, depending on the flange surface of the motor
- \*If no suitable size available, please contact

DR200			单级/One-stage									双级/Two-stage								
速比 <sup>(1)</sup> Speed ratio	i		4	5	6	7	8	9	10	16	20	16	20	25	35	40	50	70	100	
额定输出力矩( $n_{1N}$ ) Rated output torque	$T_{2N}$	Nm	1050	1200	1100	1100	1000	900	900	1000	900	1050	1050	1200	1100	1020	1200	1100	900	
紧急制动力矩 (在减速机使用寿命内允许1000次) (1000 times during the working life of the reducer)	$T_{2NOT}$	Nm	3倍额定输出力矩/3 Times rated output torque																	
额定输入转速( $T_{2n}$ , 20°C环境温度) Rated input speed ( $T_{2n}$ , 20°C ambient temperature)	$n_{1N}$	rpm	3000																	
最大输入转速 Maximum input speed	$n_{1max}$	rpm	6000																	
空载力矩( $n_1=3000rpm$ , 20°C环境温度) No-load torque ( $n_1=3000RPM$ , 20°C ambient temperature)	$T_{012}$	Nm	13	12	11	9	7.5	6.5	5.5	5.5	5	11	11	9	9	8	7	6.8	5	
回程间隙PS Backlash PS	$j_t$	Arcmin	≤2									≤3								
回程间隙P0 Backlash P0	$j_t$	Arcmin	≤4									≤5								
回程间隙P1 Backlash P1	$j_t$	Arcmin	≤6									≤7								
回程间隙P2 Backlash P2	$j_t$	Arcmin	≤8									≤9								
扭转刚度 Torsional stiffness	$C_{t21}$	Nm/Arcmin	145																	
最大轴向力 <sup>(2)</sup> Maximum axial force	$F_{2AMax}$	N	30000																	
最大倾侧力矩 Maximum bending torque	$F_{2RMax}$	Nm	3100																	
工作效率 Work efficiency	$\eta$	%	95									92								
工作寿命 <sup>(3)</sup> Service life	$L_h$	h	20000																	
噪音( $i=10$ 和 $n_1=3000rpm$ , 空载) Noise( $i=10$ and $n_1=3000rpm$ , no load)	$L_{PA}$	DB(A)	≤72																	
重量 Weight	m	Kg	42									40								
安装方向 Installation direction			任意方向/Any direction																	
使用温度 <sup>(4)</sup> Operating temperature	°C		-10~90																	
润滑方式 Lubrication method			终生润滑/Lifetime lubrication																	
防护等级 Protection level			IP65																	
转动惯量 Moment of inertia 按减速机输入直径(mm) Input diameter based on the reducer(mm)	24	$J_1$	Kgcm <sup>2</sup>	35	30	25	23	22	20	19	5.2	5	9	8.8	8.2	7.9	7.5	6.8	6.2	5.5
	32	$J_1$	Kgcm <sup>2</sup>	41	37	36	35	32	30	28	9	8	11.4	10.9	10.2	9.8	9.7	9.3	9.0	8.5
	35	$J_1$	Kgcm <sup>2</sup>	50	44	42	40	38	36	36	2.1	20	12.1	11	10.5	10.2	10	9.9	9.8	9.5

1. 可选其他减速比  
2. 输出轴中心点  
3. 连续运转时, 使用寿命为10000h  
4. 对温度有特殊要求请联系

1. Optional other ratio  
2. Output shaft center point  
3. Service life of 10000h in continuous operation  
4. For special requirements on temperature, please contact



DR255			单级/One-stage									双级/Two-stage								
速比 <sup>(1)</sup> Speed ratio	i		4	5	6	7	8	9	10	16	20	16	20	25	35	40	50	70	100	
额定输出力矩( $n_{1N}$ ) Rated output torque	$T_{2N}$	Nm	1700	2000	1800	1800	1600	1500	1500	1600	1500	1700	1700	2000	1800	1700	2000	1800	1500	
紧急制动力矩 Emergency braking torque (在减速机使用寿命内允许1000次) (1000 times during the working life of the reducer)	$T_{2NOT}$	Nm	3倍额定输出力矩/3 Times rated output torque																	
额定输入转速( $T_{2n}$ , 20°C环境温度) Rated input speed ( $T_{2n}$ , 20 °C ambient temperature)	$n_{1N}$	rpm	2000																	
最大输入转速 Maximum input speed	$n_{1max}$	rpm	4000																	
空载力矩( $n_l=3000rpm$ , 20°C环境温度) No-load torque ( $n_l=3000 RPM, 20^\circ C$ ambient temperature)	$T_{012}$	Nm	22	17	8	6	5	4.5	3.5	3.4	3.2	11	11	9	9	8	7	6.8	5	
回程间隙PS Backlash PS	$j_t$	Arcmin	$\leq 2$									$\leq 3$								
回程间隙P0 Backlash P0	$j_t$	Arcmin	$\leq 4$									$\leq 5$								
回程间隙P1 Backlash P1	$j_t$	Arcmin	$\leq 6$									$\leq 7$								
回程间隙P2 Backlash P2	$j_t$	Arcmin	$\leq 8$									$\leq 9$								
扭转刚度 Torsional stiffness	$C_{121}$	Nm/Arcmin	225																	
最大轴向力 <sup>(2)</sup> Maximum axial force	$F_{2AMax}$	N	30000																	
最大倾侧力矩 Maximum bending torque	$F_{2RMax}$	Nm	5900																	
工作效率 Work efficiency	$\eta$	%	95									92								
工作寿命 <sup>(3)</sup> Service life	$L_h$	h	20000																	
噪音 ( $i=10$ 和 $n_l=3000rpm$ , 空载) Noise ( $i=10$ and $n_l=3000rpm$ , no load)	$L_{PA}$	DB(A)	$\leq 74$																	
重量 Weight	m	Kg	78									77								
安装方向 Installation direction			任意方向/Any direction																	
使用温度 <sup>(4)</sup> Operating temperature	$^{\circ}C$		-10~90																	
润滑方式 Lubrication method			终生润滑/Lifetime lubrication																	
防护等级 Protection level			IP65																	
转动惯量 Moment of inertia 按减速机输入直径(mm) Input diameter based on the reducer(mm)	42	$J_1$	Kgcm <sup>2</sup>	70	68	65	55	52	45	40	40	35	16	5.5	14	14	13	12	10.8	9.5
	55	$J_1$	Kgcm <sup>2</sup>	95	77	75	68	65	60	55	54	50	28	27	26.5	25.5	24	23	21	19.5

1. 可选其他减速比  
2. 输出轴中心点  
3. 连续运转时, 使用寿命为10000h  
4. 对温度有特殊要求请联系

1. Optional other ratio  
2. Output shaft center point  
3. Service life of 10000h in continuous operation  
4. For special requirements on temperature, please contact

单级/One-stage

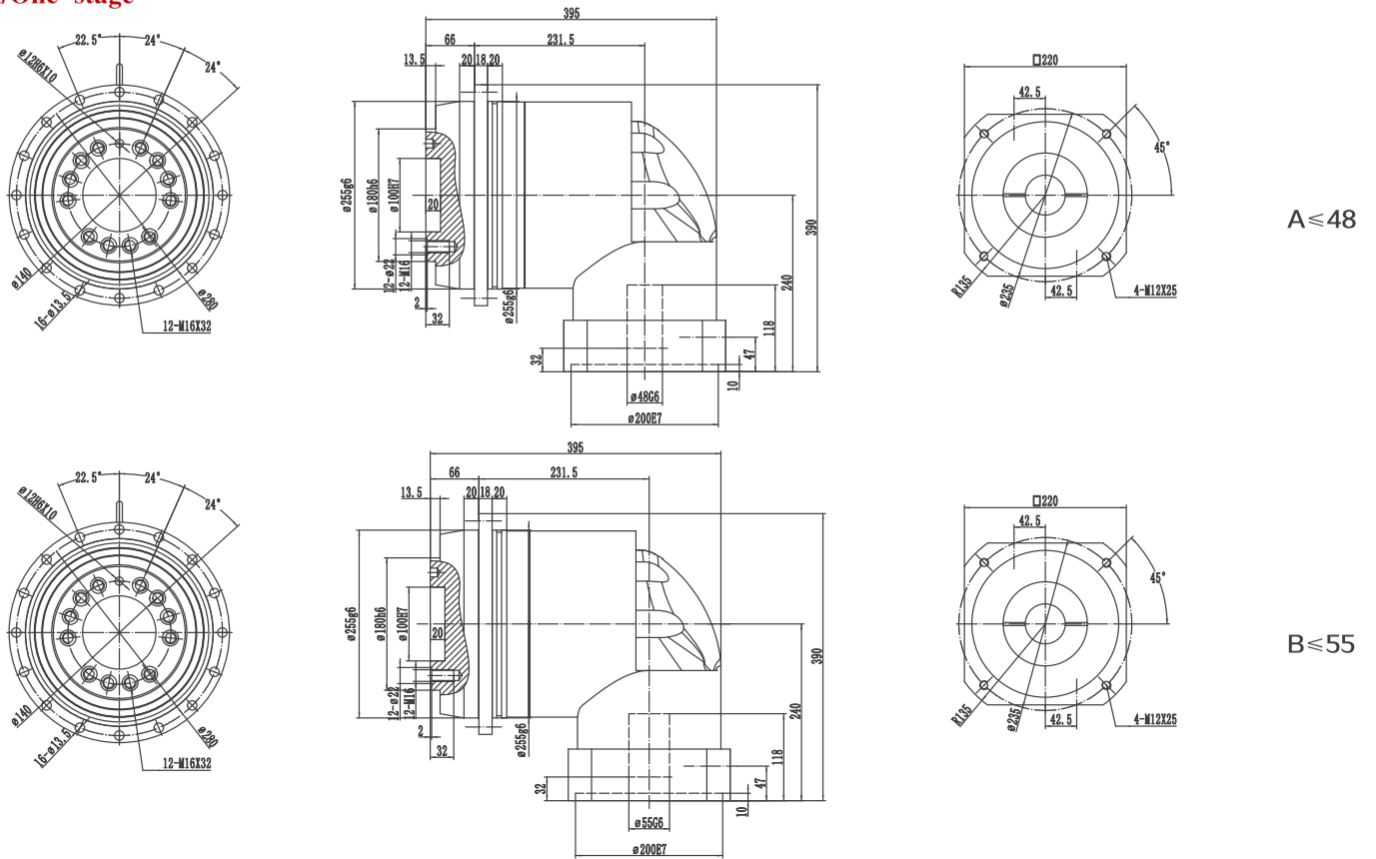

双级/Two-stage

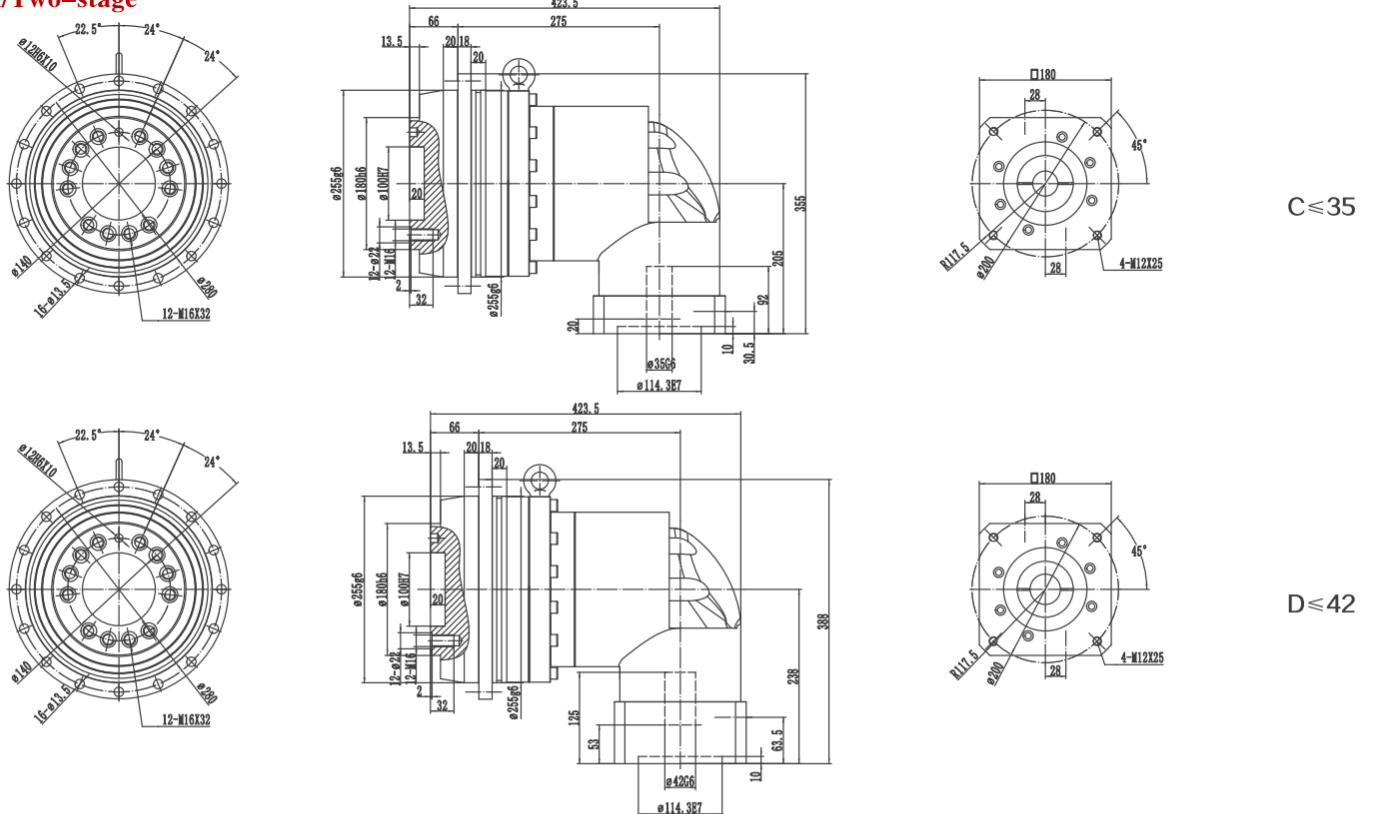

- (1) 请参照马达轴径尺寸
  - (2) 马达轴最长长度, 如有特殊的马达轴尺寸, 请联系
  - (3) 减速机输入端尺寸, 依马达的法兰面而定
- \*如无适合的尺寸, 请联系

- (1) Please refer to the motor shaft diameter
  - (2) Motor shaft length, for special motor shaft size, please contact
  - (3) Reducer input size, depending on the flange surface of the motor
- \*If no suitable size available, please contact