

D系列—高度灵活

D SERIES—HIGHLY FLEXIBLE

xulong

D系列能够在设计、装配和应用上提供最大的灵活性。其突出特点是功率密度高且回程间隙低，特别适合需要高效率 and 扭转刚度的高精度应用。

The D series can provide maximum flexibility in design, assembly and application. Its outstanding characteristics are high power density and low backlash clearance, especially suitable for high-precision applications requiring high efficiency and torsional rigidity.

技术参数* TECHNICAL PARAMETERS

回程间隙 Return clearance	arcmin	1~7
速比 Speed ratio	i	4~100
额定输出力矩 Rated output torque	Nm	14~2000
使用温度°C Using temperature°C	°C	-10~90
噪音 The noise	dB(A)	56~70
工作效率 The work efficiency	%	97
工作寿命 The working life	h	20000

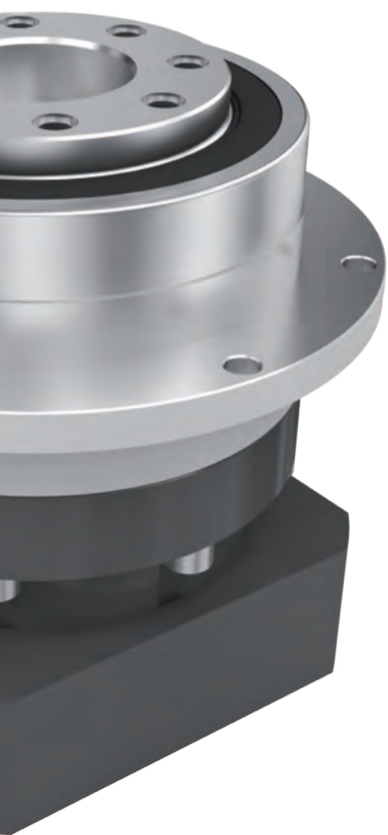

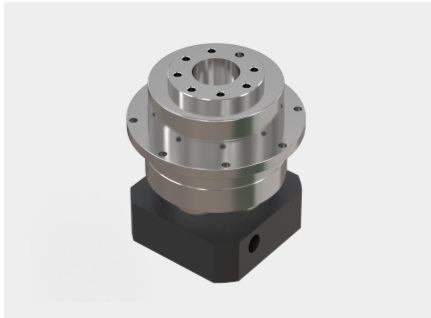
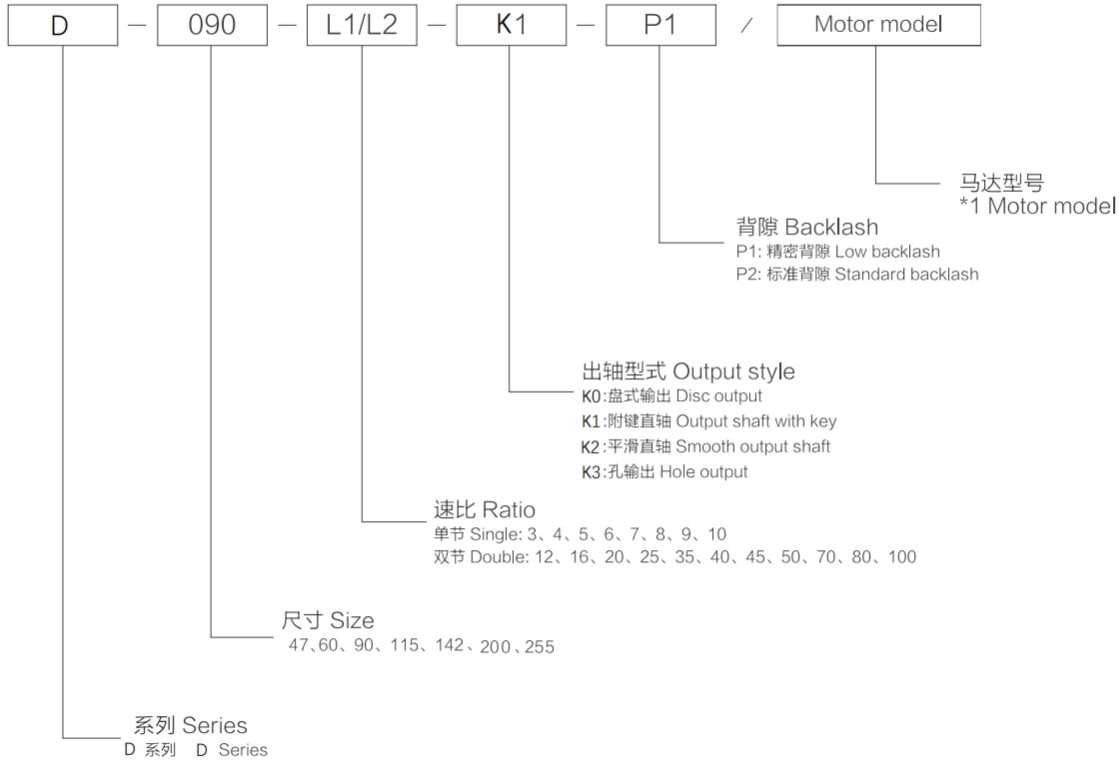

D系列—高度灵活
D series-highly flexible



将太阳齿轮输出轴承直接设臂架内, 确保精度和同心度
The sun gear output bearing is directly set inside the arm frame to ensure accuracy and concentricity

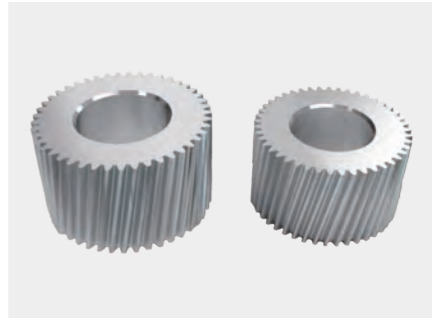

齿面宽, 参数做大, 实现高强度
The tooth surface is wide, the parameters are larger, and the high strength is achieved



太阳齿一体式设计, 确保同心度和扭转刚性
Integrated solar tooth design ensures concentricity and torsional rigidity

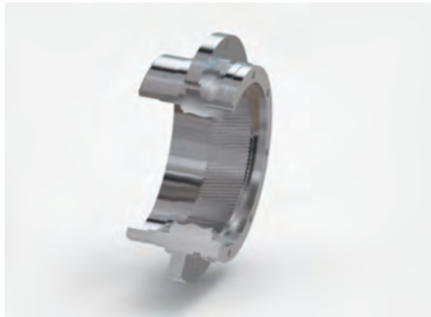

先进表面处理耐磨, 耐刮, 耐腐蚀
Advanced surface treatment wear-resistant, scratch-resistant, corrosion-resistant

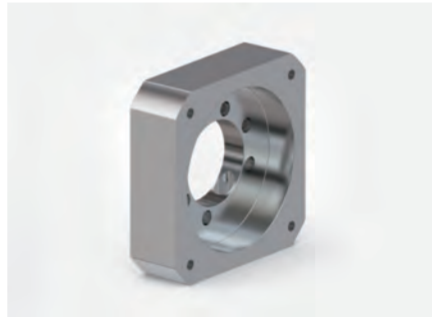

一体化连接板设计, 与各种伺服, 马达完美配合
Integrated connection board design, perfect coordination with various servo and motors

D047			单级/One-stage							双级/Two-stage								
速比 ⁽¹⁾ Speed ratio	i		4	5	6	7	8	9	10	16	20	25	35	40	50	70	100	
额定输出力矩(n_{1N}) Rated output torque	T_{2N}	Nm	19	22	20	19	17	14	14	19	19	22	19	17	22	19	14	
紧急制动力矩 Emergency braking torque (在减速机工作寿命内允许1000次) (1000 times during the working life of the reducer)	T_{2NOT}	Nm	3倍额定输出力矩/3 Times rated output torque															
额定输入转速(T_{2n} , 20°C环境温度) Rated input speed (T_{2n} , 20 °C ambient temperature)	n_{1N}	rpm	5000															
最大输入转速 Maximum input speed	n_{1max}	rpm	10000															
空载力矩($n_1=3000rpm$, 20°C环境温度) No-load torque ($n_1=3000 RPM, 20^\circ C$ ambient temperature)	T_{012}	Nm	0.4	0.4	0.3	0.3	0.2	0.2	0.2	0.3	0.3	0.3	0.3	0.3	0.2	0.2	0.1	
回程间隙PS Backlash PS	j_t	Arcmin	≤ 1							≤ 2								
回程间隙P0 Backlash P0	j_t	Arcmin	≤ 2							≤ 3								
回程间隙P1 Backlash P1	j_t	Arcmin	≤ 3							≤ 5								
回程间隙P2 Backlash P2	j_t	Arcmin	≤ 5							≤ 7								
扭转刚度 Torsional stiffness	C_{t21}	Nm/Arcmin	3															
最大轴向力 ⁽²⁾ Maximum axial force	F_{2AMax}	N	990															
最大倾侧力矩 Maximum bending torque	F_{2RMax}	Nm	43															
工作效率 Work efficiency	η	%	97							94								
工作寿命 ⁽³⁾ Service life	L_h	h	20000															
噪音 ($i=10$ 和 $n_1=3000rpm$, 空载) Noise ($i=10$ and $n_1=3000rpm$, no load)	L_{PA}	DB(A)	≤ 56															
重量 Weight	m	Kg	0.6							0.8								
安装方向 Installation direction			任意方向/Any direction															
使用温度 ⁽⁴⁾ Operating temperature	°C		-10~90															
润滑方式 Lubrication method			终生润滑/Lifetime lubrication															
防护等级 Protection level			IP65															
转动惯量 Moment of inertia 按减速机输入直径(mm) Input diameter based on the reducer(mm)	8	J_1	Kgcm ²	0.06	0.05	0.05	0.04	0.03	0.03	0.03	0.03	0.03	0.03	0.03	0.03	0.02	0.02	0.02
	11	J_1	Kgcm ²	0.13	0.12	0.12	0.12	0.11	0.07	0.06	0.1	0.08	0.08	0.07	0.07	0.06	0.06	0.05
	14	J_1	Kgcm ²	0.16	0.15	0.14	0.13	0.12	0.09	0.08	0.12	0.11	0.1	0.1	0.09	0.09	0.07	0.06

1. 可选其他减速比
2. 输出轴中心点
3. 连续运转时, 使用寿命为10000h
4. 对温度有特殊要求请联系

1. Optional other ratio
2. Output shaft center point
3. Service life of 10000h in continuous operation
4. For special requirements on temperature, please contact

D064			单级/One-stage							双级/Two-stage							
速比 ⁽¹⁾ Speed ratio	i		4	5	6	7	8	9	10	16	20	25	35	40	50	70	100
额定输出力矩(n_{1N}) Rated output torque	T_{2N}	Nm	50	60	55	50	45	40	40	50	50	60	50	50	55	50	40
紧急制动力矩 Emergency braking torque (在减速机使用寿命内允许1000次) (1000 times during the working life of the reducer)	T_{2NOT}	Nm	3倍额定输出力矩/3 Times rated output torque														
额定输入转速(T_{2n} , 20°C环境温度) Rated input speed (T_{2n} , 20 °C ambient temperature)	n_{1N}	rpm	4000														
最大输入转速 Maximum input speed	n_{1max}	rpm	8000														
空载力矩($n_1=3000rpm$, 20°C环境温度) No-load torque ($n_1=3000 RPM$, 20°C ambient temperature)	T_{012}	Nm	0.8	0.8	0.7	0.6	0.5	0.5	0.4	0.6	0.55	0.5	0.5	0.4	0.4	0.35	0.3
回程间隙PS Backlash PS	j_t	Arcmin	≤ 1							≤ 2							
回程间隙P0 Backlash P0	j_t	Arcmin	≤ 2							≤ 3							
回程间隙P1 Backlash P1	j_t	Arcmin	≤ 3							≤ 5							
回程间隙P2 Backlash P2	j_t	Arcmin	≤ 5							≤ 7							
扭转刚度 Torsional stiffness	C_{121}	Nm/Arcmin	4.5														
最大轴向力 ⁽²⁾ Maximum axial force	F_{2AMax}	N	1050														
最大倾侧力矩 Maximum bending torque	F_{2RMax}	Nm	125														
工作效率 Work efficiency	η	%	97							94							
工作寿命 ⁽³⁾ Service life	L_h	h	20000														
噪音 ($i=10$ 和 $n_1=3000rpm$, 空载) Noise ($i=10$ and $n_1=3000rpm$, no load)	L_{PA}	DB(A)	≤ 58														
重量 Weight	m	Kg	1.3							1.8							
安装方向 Installation direction			任意方向/Any direction														
使用温度 ⁽⁴⁾ Operating temperature	°C		-10~90														
润滑方式 Lubrication method			终生润滑/Lifetime lubrication														
防护等级 Protection level			IP65														
转动惯量 Moment of inertia 按减速机输入直径(mm) Input diameter based on the reducer(mm)	11	J_1	Kgcm ²	0.2	0.2	0.15	0.13	0.12	0.1	0.1	0.1	0.09	0.08	0.08	0.08	0.08	0.08
	14	J_1	Kgcm ²	0.25	0.25	0.22	0.18	0.17	0.15	0.14	0.17	0.17	0.16	0.16	0.16	0.16	0.15
	19	J_1	Kgcm ²	0.6	0.55	0.55	0.52	0.5	0.5	0.5	0.5	0.18	0.16	0.15	0.15	0.15	0.14

1. 可选其他减速比
2. 输出轴中心点
3. 连续运转时, 使用寿命为10000h
4. 对温度有特殊要求请联系

1. Optional other ratio
2. Output shaft center point
3. Service life of 10000h in continuous operation
4. For special requirements on temperature, please contact

单级/One-stage

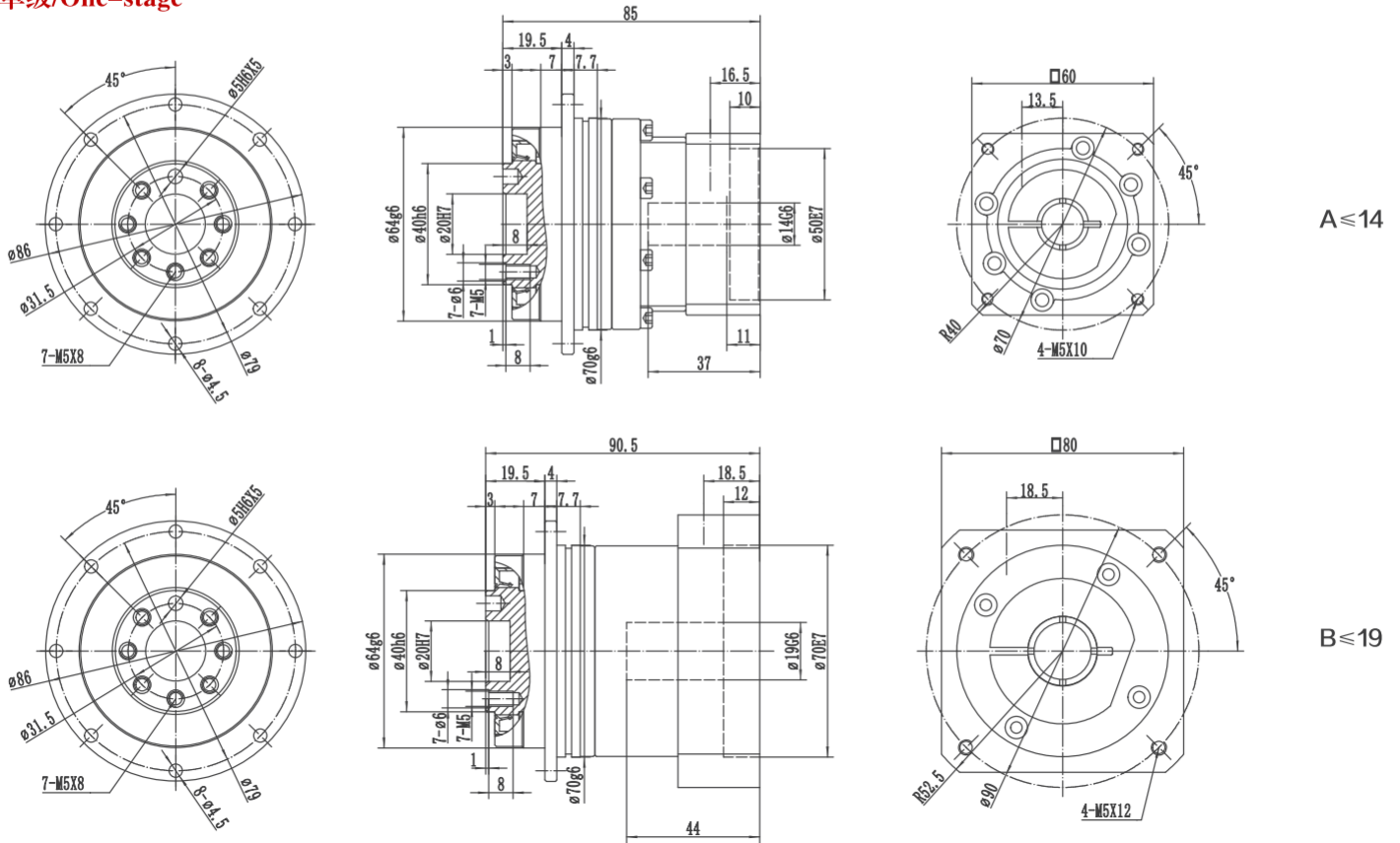

双级/Two-stage

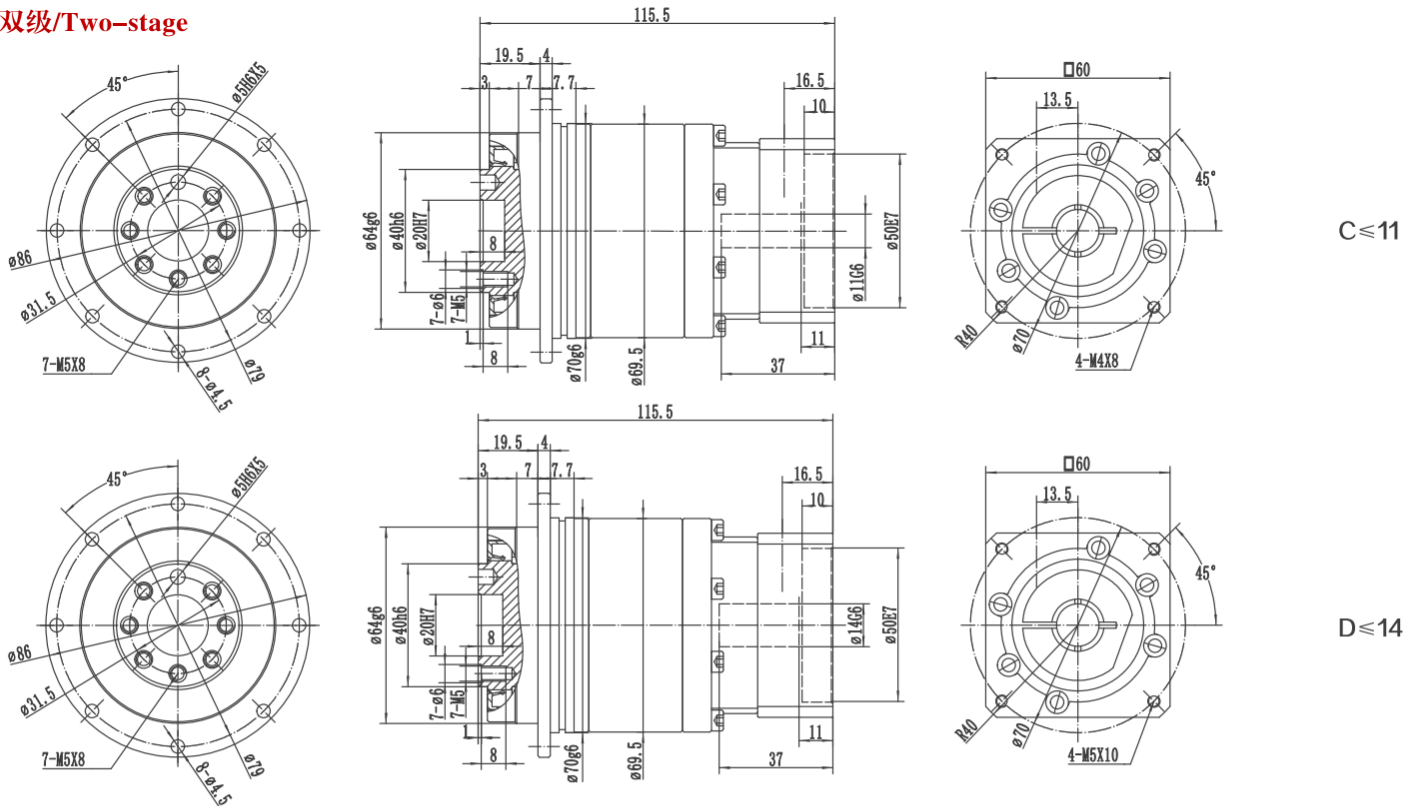

(1) 请参照马达轴径尺寸
 (2) 马达轴最长长度, 如有特殊的马达轴尺寸, 请联系
 (3) 减速机输入端尺寸, 依马达的法兰面而定
 *如无适合的尺寸, 请联系

(1) Please refer to the motor shaft diameter
 (2) Motor shaft length, for special motor shaft size, please contact
 (3) Reducer input size, depending on the flange surface of the motor
 *If no suitable size available, please contact

D090			单级/One-stage							双级/Two-stage								
速比 ⁽¹⁾ Speed ratio	i		4	5	6	7	8	9	10	16	20	25	35	40	50	70	100	
额定输出力矩(n_{1N}) Rated output torque	T_{2N}	Nm	140	160	140	140	120	100	100	140	140	160	140	140	160	120	100	
紧急制动力矩 Emergency braking torque (在减速机使用寿命内允许1000次) (1000 times during the working life of the reducer)	T_{2NOT}	Nm	3倍额定输出力矩/3 Times rated output torque															
额定输入转速(T_{2n} , 20°C环境温度) Rated input speed (T_{2n} , 20 °C ambient temperature)	n_{1N}	rpm	3000															
最大输入转速 Maximum input speed	n_{1max}	rpm	6000															
空载力矩($n_1=3000rpm$, 20°C环境温度) No-load torque ($n_1=3000$ RPM, 20°C ambient temperature)	T_{012}	Nm	1.7	1.6	1.5	1.4	1.1	0.8	0.7	0.8	0.7	0.6	0.5	0.5	0.4	0.3	0.3	
回程间隙PS Backlash PS	j_t	Arcmin	≤ 1							≤ 2								
回程间隙P0 Backlash P0	j_t	Arcmin	≤ 2							≤ 3								
回程间隙P1 Backlash P1	j_t	Arcmin	≤ 3							≤ 5								
回程间隙P2 Backlash P2	j_t	Arcmin	≤ 5							≤ 7								
扭转刚度 Torsional stiffness	C_{121}	Nm/Arcmin	14															
最大轴向力 ⁽²⁾ Maximum axial force	F_{2AMax}	N	2850															
最大倾侧力矩 Maximum bending torque	F_{2RMax}	Nm	235															
工作效率 Work efficiency	η	%	97							94								
工作寿命 ⁽³⁾ Service life	L_h	h	20000															
噪音 ($i=10$ 和 $n_1=3000rpm$, 空载) Noise ($i=10$ and $n_1=3000rpm$, no load)	L_{PA}	DB(A)	≤ 60															
重量 Weight	m	Kg	3.9							4.6								
安装方向 Installation direction			任意方向/Any direction															
使用温度 ⁽⁴⁾ Operating temperature	°C		-10~90															
润滑方式 Lubrication method			终生润滑/Lifetime lubrication															
防护等级 Protection level			IP65															
转动惯量 Moment of inertia 按减速机输入直径(mm) Input diameter based on the reducer(mm)	19	J_1	Kgcm ²	1.3	1.2	1.1	0.9	0.8	0.7	0.6	0.23	0.21	0.2	0.18	0.18	0.18	0.16	0.16
	22	J_1	Kgcm ²	2.1	2	2	1.8	1.7	1.5	1.5	0.7	0.7	0.7	0.7	0.7	0.6	0.5	0.5
	24	J_1	Kgcm ²	2.4	2.3	2.3	2.2	2.2	2.1	2.1	0.8	0.07	0.7	0.7	0.7	0.65	0.6	0.6

1. 可选其他减速比
2. 输出轴中心点
3. 连续运转时, 使用寿命为10000h
4. 对温度有特殊要求请联系

1. Optional other ratio
2. Output shaft center point
3. Service life of 10000h in continuous operation
4. For special requirements on temperature, please contact

单级/One-stage

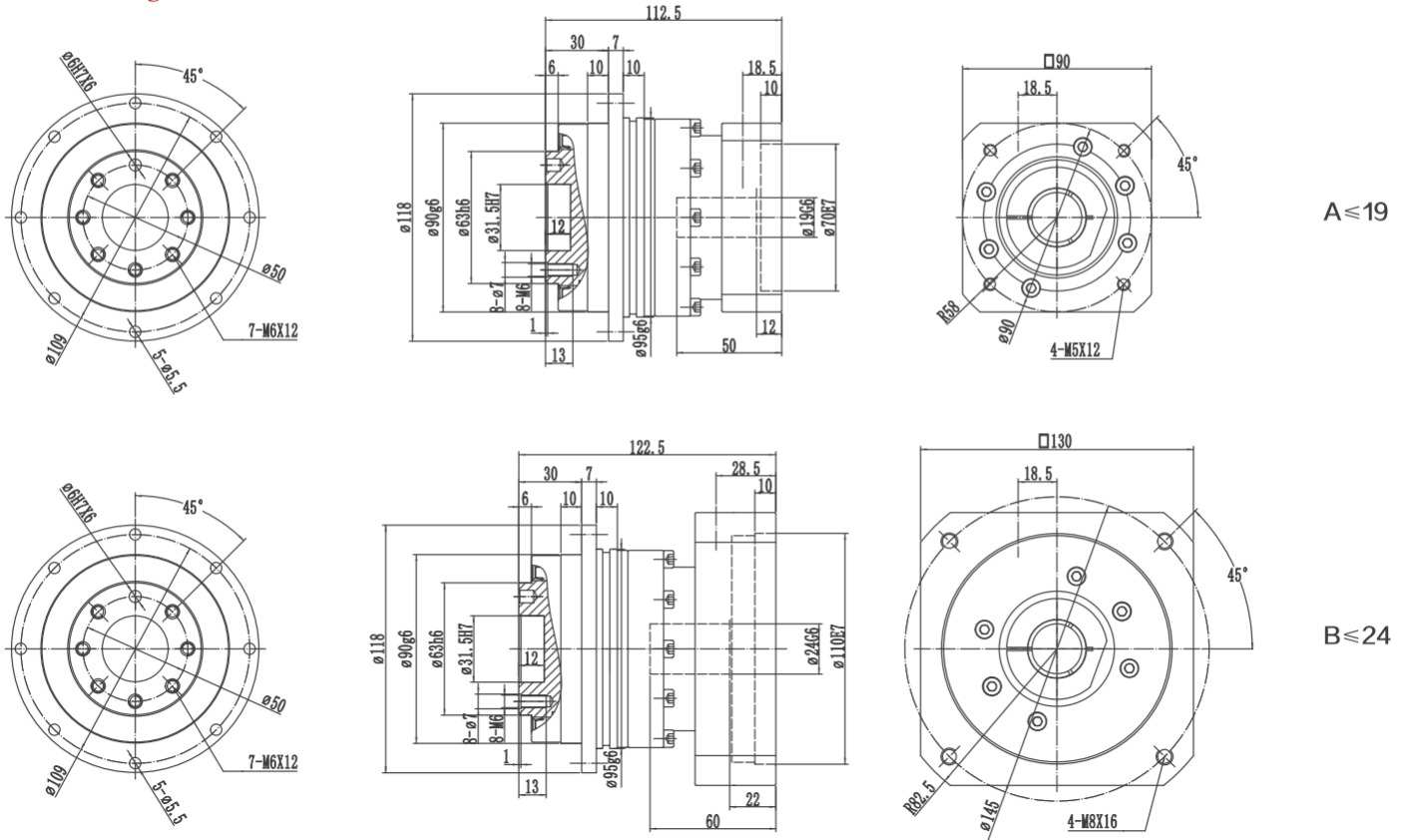

双级/Two-stage

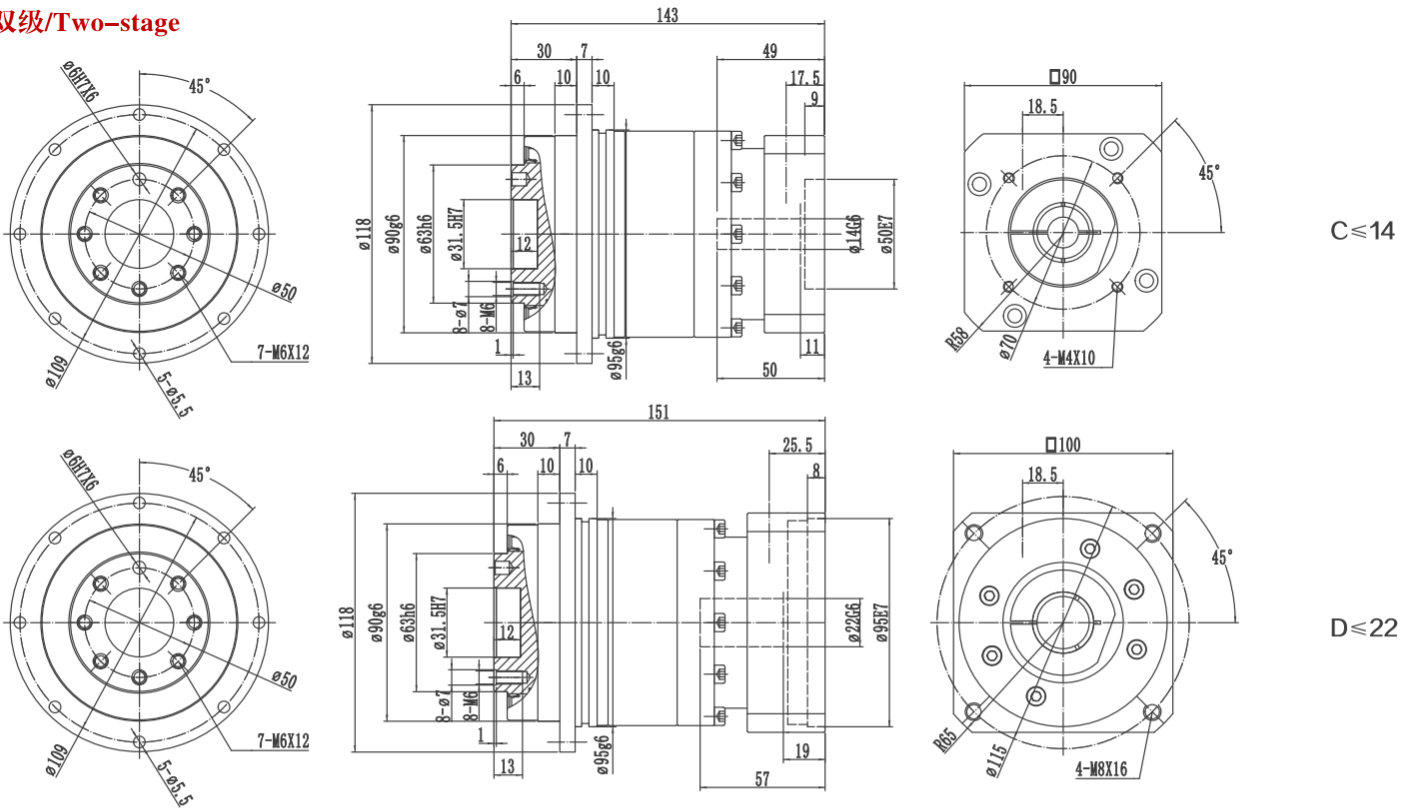

(1) 请参照马达轴径尺寸
 (2) 马达轴最长长度, 如有特殊的马达轴尺寸, 请联系
 (3) 减速机输入端尺寸, 依马达的法兰面而定
 *如无适合的尺寸, 请联系

(1) Please refer to the motor shaft diameter
 (2) Motor shaft length, for special motor shaft size, please contact
 (3) Reducer input size, depending on the flange surface of the motor
 *If no suitable size available, please contact

D110			单级/One-stage							双级/Two-stage								
速比 ⁽¹⁾ Speed ratio	i		4	5	6	7	8	9	10	16	20	25	35	40	50	70	100	
额定输出力矩(n_{1N}) Rated output torque	T_{2N}	Nm	290	330	300	300	260	230	230	290	290	330	300	330	330	300	230	
紧急制动力矩 Emergency braking torque (在减速机使用寿命内允许1000次) (1000 times during the working life of the reducer)	T_{2NOT}	Nm	3倍额定输出力矩/3 Times rated output torque															
额定输入转速(T_{2n} , 20°C环境温度) Rated input speed (T_{2n} , 20 °C ambient temperature)	n_{1N}	rpm	3000															
最大输入转速 Maximum input speed	n_{1max}	rpm	6000															
空载力矩($n_1=3000rpm$, 20°C环境温度) No-load torque ($n_1=3000 RPM$, 20°C ambient temperature)	T_{012}	Nm	3	2.7	2.5	2	1.8	1.6	1.5	1.6	1.6	1.5	1.2	1	0.8	0.7	0.6	
回程间隙PS Backlash PS	j_t	Arcmin	≤ 1							≤ 2								
回程间隙P0 Backlash P0	j_t	Arcmin	≤ 2							≤ 3								
回程间隙P1 Backlash P1	j_t	Arcmin	≤ 3							≤ 5								
回程间隙P2 Backlash P2	j_t	Arcmin	≤ 5							≤ 7								
扭转刚度 Torsional stiffness	C_{t21}	Nm/Arcmin	25															
最大轴向力 ⁽²⁾ Maximum axial force	F_{2AMax}	N	2990															
最大倾侧力矩 Maximum bending torque	F_{2RMax}	Nm	430															
工作效率 Work efficiency	η	%	97							94								
工作寿命 ⁽³⁾ Service life	L_h	h	20000															
噪音 ($i=10$ 和 $n_1=3000rpm$, 空载) Noise ($i=10$ and $n_1=3000rpm$, no load)	L_{PA}	DB(A)	≤ 63															
重量 Weight	m	Kg	8.7							10								
安装方向 Installation direction			任意方向/Any direction															
使用温度 ⁽⁴⁾ Operating temperature	°C		-10~90															
润滑方式 Lubrication method			终生润滑/Lifetime lubrication															
防护等级 Protection level			IP65															
转动惯量 Moment of inertia 按减速机输入直径(mm) Input diameter based on the reducer(mm)	19	J_1	Kgcm ²	3	2.6	2.2	2	1.8	1.6	1.5	0.7	0.7	0.7	0.7	0.7	0.6	0.5	0.5
	24	J_1	Kgcm ²	4.6	4.5	4	3.5	3	2.7	2.5	1.8	1.8	1.7	1.7	1.6	1.4	1.4	1.4
	35	J_1	Kgcm ²	10.5	10	10	9.9	9.9	9.6	9.5	2.1	2.1	2	2	1.9	1.8	1.8	1.7

1. 可选其他减速比
2. 输出轴中心点
3. 连续运转时, 使用寿命为10000h
4. 对温度有特殊要求请联系

1. Optional other ratio
2. Output shaft center point
3. Service life of 10000h in continuous operation
4. For special requirements on temperature, please contact

单级/One-stage

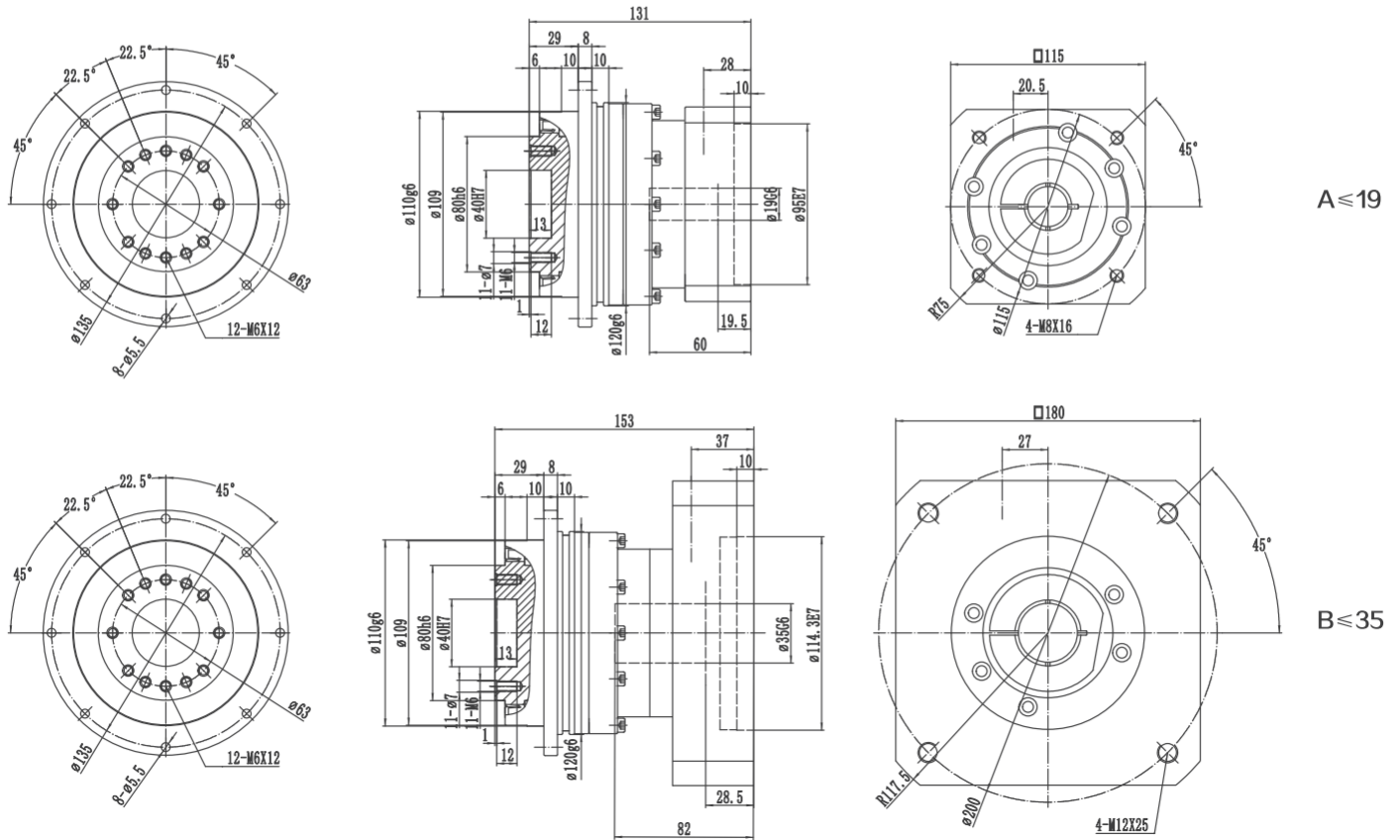

双级/Two-stage

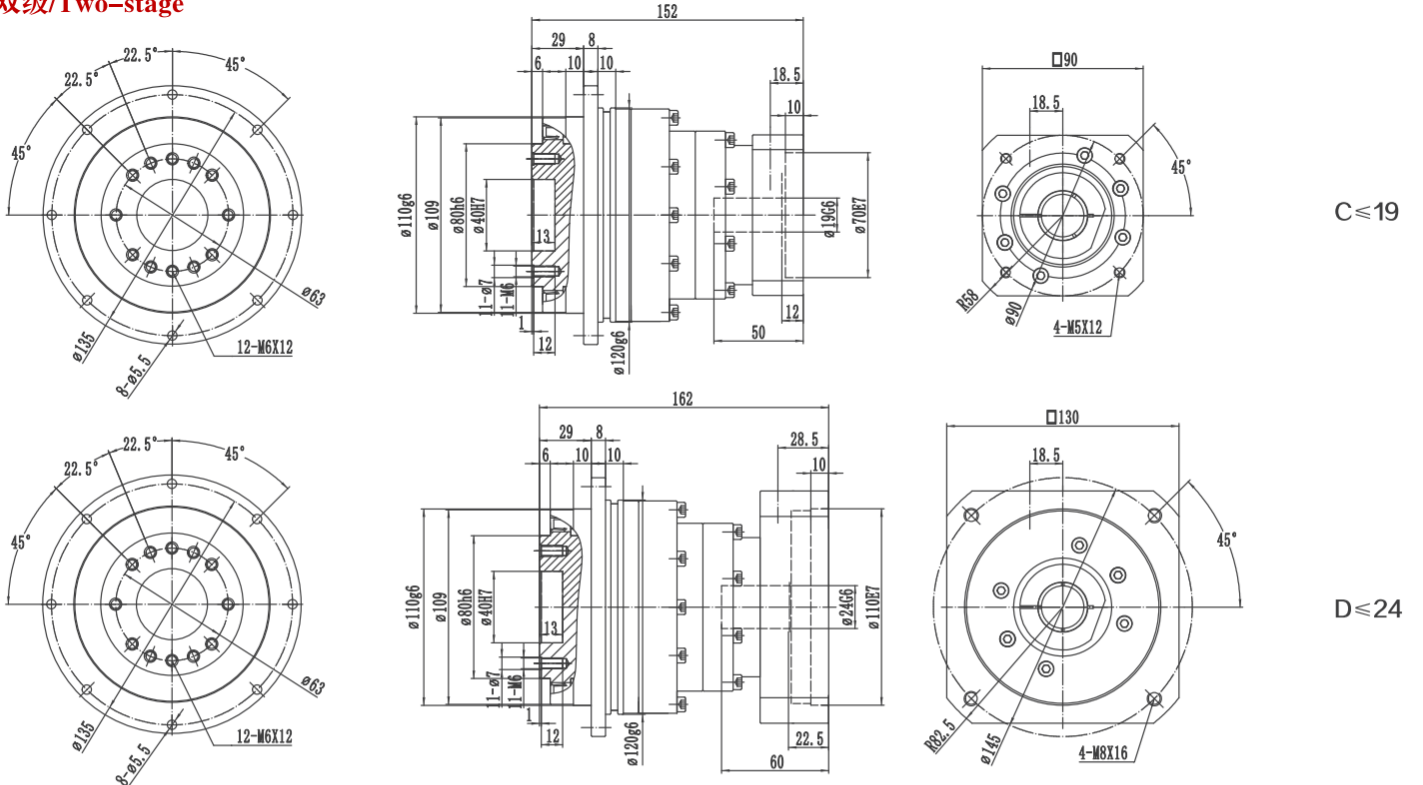

(1) 请参照马达轴径尺寸
 (2) 马达轴最长长度, 如有特殊的马达轴尺寸, 请联系
 (3) 减速机输入端尺寸, 依马达的法兰面而定
 *如无适合的尺寸, 请联系

(1) Please refer to the motor shaft diameter
 (2) Motor shaft length, for special motor shaft size, please contact
 (3) Reducer input size, depending on the flange surface of the motor
 *If no suitable size available, please contact

D142			单级/One-stage							双级/Two-stage								
速比 ⁽¹⁾ Speed ratio	i		4	5	6	7	8	9	10	16	20	25	35	40	50	70	100	
额定输出力矩(n_{1N}) Rated output torque	T_{2N}	Nm	542	650	550	550	500	450	450	542	542	650	550	542	650	550	450	
紧急制动力矩 Emergency braking torque (在减速机使用寿命内允许1000次) (1000 times during the working life of the reducer)	T_{2NOT}	Nm	3倍额定输出力矩/3 Times rated output torque															
额定输入转速(T_{2n} , 20°C环境温度) Rated input speed (T_{2n} , 20 °C ambient temperature)	n_{1N}	rpm	3000															
最大输入转速 Maximum input speed	n_{1max}	rpm	6000															
空载力矩($n_1=3000rpm$, 20°C环境温度) No-load torque ($n_1=3000 RPM$, 20°C ambient temperature)	T_{012}	Nm	6	4.7	4.5	3.5	2.5	2.5	2.5	2.8	2.6	2.2	2.0	1.9	1.8	1.6	1.5	
回程间隙PS Backlash PS	j_t	Arcmin	≤ 1							≤ 2								
回程间隙P0 Backlash P0	j_t	Arcmin	≤ 2							≤ 3								
回程间隙P1 Backlash P1	j_t	Arcmin	≤ 3							≤ 5								
回程间隙P2 Backlash P2	j_t	Arcmin	≤ 5							≤ 7								
扭转刚度 Torsional stiffness	C_{121}	Nm/Arcmin	50															
最大轴向力 ⁽²⁾ Maximum axial force	F_{2AMax}	N	10590															
最大倾侧力矩 Maximum bending torque	F_{2RMax}	Nm	1300															
工作效率 Work efficiency	η	%	97							94								
工作寿命 ⁽³⁾ Service life	L_h	h	20000															
噪音 ($i=10$ 和 $n_1=3000rpm$, 空载) Noise ($i=10$ and $n_1=3000rpm$, no load)	L_{PA}	DB(A)	≤ 65															
重量 Weight	m	Kg	16							20								
安装方向 Installation direction			任意方向/Any direction															
使用温度 ⁽⁴⁾ Operating temperature	°C		-10~90															
润滑方式 Lubrication method			终生润滑/Lifetime lubrication															
防护等级 Protection level			IP65															
转动惯量 Moment of inertia 按减速机输入直径(mm) Input diameter based on the reducer(mm)	19	J_1	Kgcm ²	8	8	7.2	7	6.5	5.8	5.5	2.2	2	1.7	1.7	1.6	14	14	14
	24	J_1	Kgcm ²	12	11	10	10	9.5	9.5	9	3.2	3	2.9	2.7	2.5	2.3	2.2	2
	35	J_1	Kgcm ²	25	24.5	24.1	23.5	23	22.5	22	12	11	10	10	9.5	9.5	9	9

1. 可选其他减速比
2. 输出轴中心点
3. 连续运转时, 使用寿命为10000h
4. 对温度有特殊要求请联系

1. Optional other ratio
2. Output shaft center point
3. Service life of 10000h in continuous operation
4. For special requirements on temperature, please contact

D200			单级/One-stage							双级/Two-stage								
速比 ⁽¹⁾ Speed ratio	i		4	5	6	7	8	9	10	16	20	25	35	40	50	70	100	
额定输出力矩(n_{1N}) Rated output torque	T_{2N}	Nm	1050	1200	1100	1100	1000	900	900	1050	1050	1200	1100	1020	1200	1100	900	
紧急制动力矩 Emergency braking torque (在减速机使用寿命内允许1000次) (1000 times during the working life of the reducer)	T_{2NOT}	Nm	3倍额定输出力矩/3 Times rated output torque															
额定输入转速(T_{2n} , 20°C环境温度) Rated input speed (T_{2n} , 20 °C ambient temperature)	n_{1N}	rpm	3000															
最大输入转速 Maximum input speed	n_{1max}	rpm	6000															
空载力矩($n_1=3000rpm$, 20°C环境温度) No-load torque ($n_1=3000 RPM$, 20°C ambient temperature)	T_{012}	Nm	13	12	11	9	7.5	6.5	5.5	2.8	2.6	2.2	2.0	1.9	1.8	1.6	1.5	
回程间隙PS Backlash PS	j_t	Arcmin	≤ 1							≤ 2								
回程间隙P0 Backlash P0	j_t	Arcmin	≤ 2							≤ 3								
回程间隙P1 Backlash P1	j_t	Arcmin	≤ 3							≤ 5								
回程间隙P2 Backlash P2	j_t	Arcmin	≤ 5							≤ 7								
扭转刚度 Torsional stiffness	C_{121}	Nm/Arcmin	145															
最大轴向力 ⁽²⁾ Maximum axial force	F_{2AMax}	N	30000															
最大倾侧力矩 Maximum bending torque	F_{2RMax}	Nm	3100															
工作效率 Work efficiency	η	%	97							94								
工作寿命 ⁽³⁾ Service life	L_h	h	20000															
噪音 ($i=10$ 和 $n_1=3000rpm$, 空载) Noise ($i=10$ and $n_1=3000rpm$, no load)	L_{PA}	DB(A)	≤ 67															
重量 Weight	m	Kg	31							39								
安装方向 Installation direction			任意方向/Any direction															
使用温度 ⁽⁴⁾ Operating temperature	°C		-10~90															
润滑方式 Lubrication method			终生润滑/Lifetime lubrication															
防护等级 Protection level			IP65															
转动惯量 Moment of inertia 按减速机输入直径(mm) Input diameter based on the reducer(mm)	35	J_1	Kgcm ²	35	30	25	23	22	20	19	9	8.8	8.2	7.9	7.5	6.8	6.2	5.5
	42	J_1	Kgcm ²	41	37	36	35	32	30	28	11.4	10.9	10.2	9.8	9.7	9.3	9.0	8.5
	55	J_1	Kgcm ²	50	44	42	40	38	36	36	12.1	11	10.5	10.2	10	9.9	9.8	9.5

1. 可选其他减速比
2. 输出轴中心点
3. 连续运转时, 使用寿命为10000h
4. 对温度有特殊要求请联系

1. Optional other ratio
2. Output shaft center point
3. Service life of 10000h in continuous operation
4. For special requirements on temperature, please contact

单级/One-stage

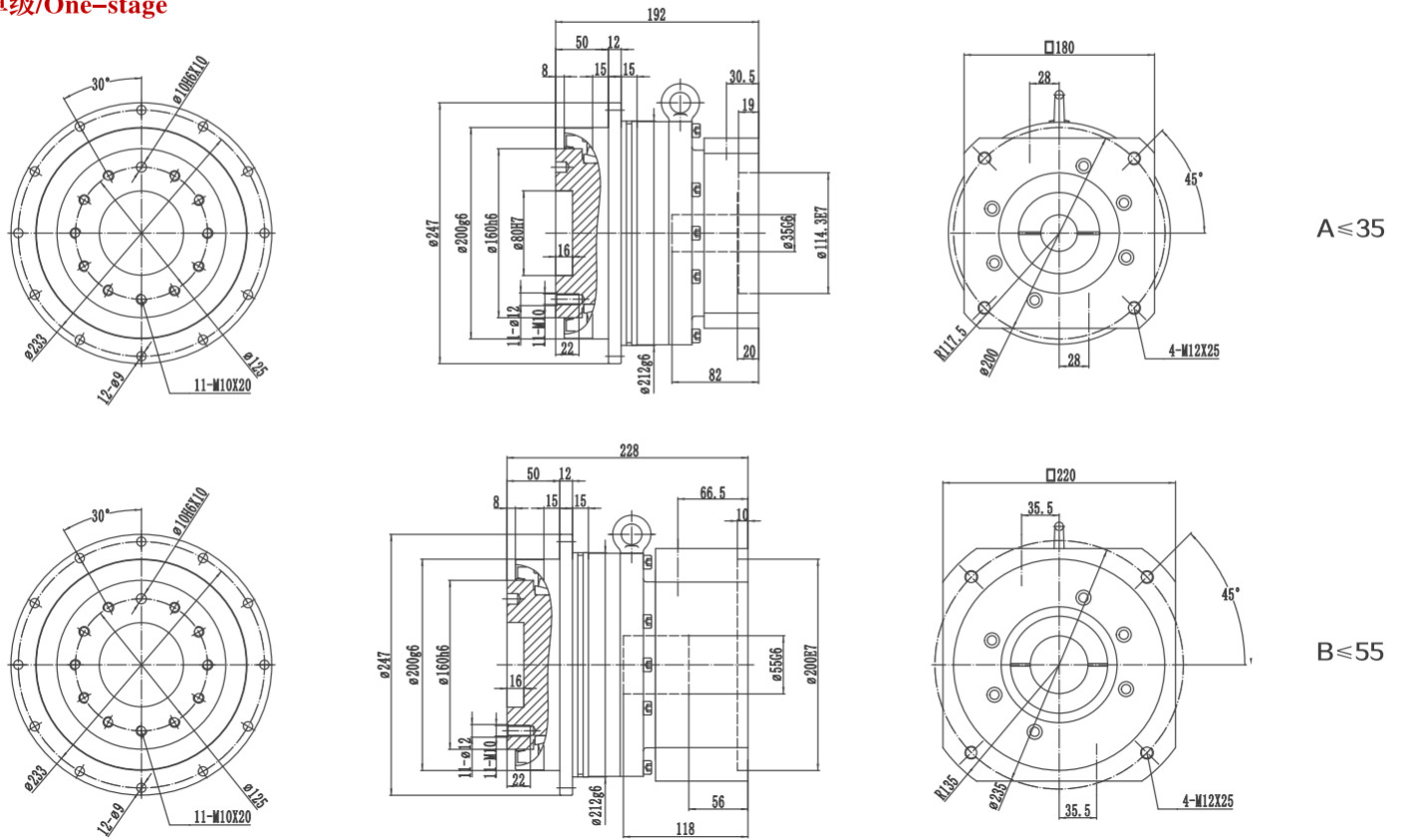

双级/Two-stage

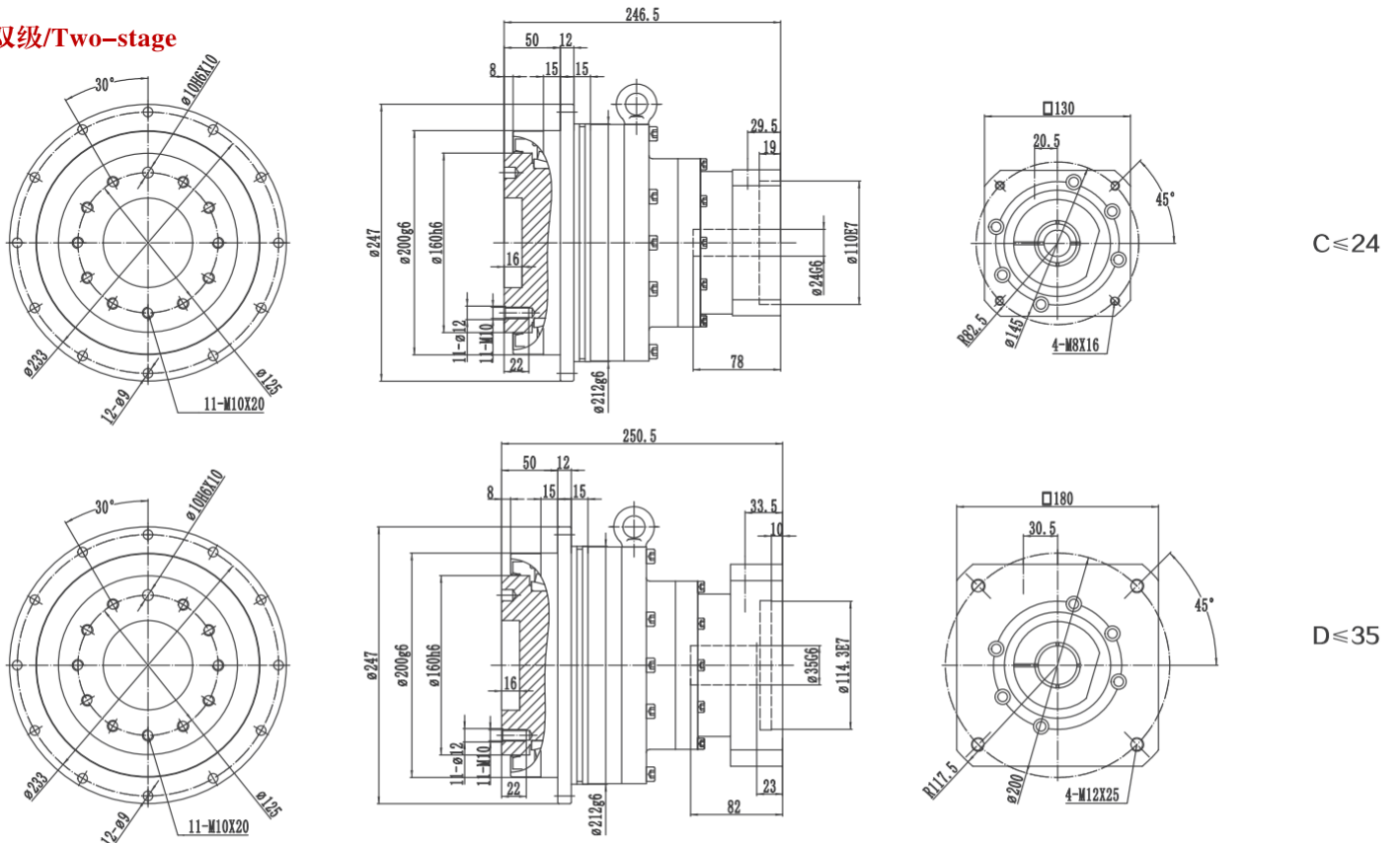

- (1) 请参照马达轴径尺寸
 - (2) 马达轴最长长度, 如有特殊的马达轴尺寸, 请联系
 - (3) 减速机输入端尺寸, 依马达的法兰面而定
- *如无适合的尺寸, 请联系

- (1) Please refer to the motor shaft diameter
 - (2) Motor shaft length, for special motor shaft size, please contact
 - (3) Reducer input size, depending on the flange surface of the motor
- *If no suitable size available, please contact

D255			单级/One-stage							双级/Two-stage								
速比 ⁽¹⁾ Speed ratio	i		4	5	6	7	8	9	10	16	20	25	35	40	50	70	100	
额定输出力矩(n_{1N}) Rated output torque	T_{2N}	Nm	1700	2000	1800	1800	1600	1500	1500	1700	1700	2000	1800	1700	2000	1800	1500	
紧急制动力矩 Emergency braking torque (在减速机使用寿命内允许1000次) (1000 times during the working life of the reducer)	T_{2NOT}	Nm	3倍额定输出力矩/3 Times rated output torque															
额定输入转速(T_{2n} , 20°C环境温度) Rated input speed (T_{2n} , 20 °C ambient temperature)	n_{1N}	rpm	2000															
最大输入转速 Maximum input speed	n_{1max}	rpm	4000															
空载力矩($n_1=3000rpm$, 20°C环境温度) No-load torque ($n_1=3000 RPM$, 20°C ambient temperature)	T_{012}	Nm	22	17	8	6	5	4.5	3.5	11	11	9	9	8	7	6.8	5	
回程间隙PS Backlash PS	j_t	Arcmin	≤ 1							≤ 2								
回程间隙P0 Backlash P0	j_t	Arcmin	≤ 2							≤ 3								
回程间隙P1 Backlash P1	j_t	Arcmin	≤ 3							≤ 5								
回程间隙P2 Backlash P2	j_t	Arcmin	≤ 5							≤ 7								
扭转刚度 Torsional stiffness	C_{121}	Nm/Arcmin	225															
最大轴向力 ⁽²⁾ Maximum axial force	F_{2AMax}	N	30000															
最大倾侧力矩 Maximum bending torque	F_{2RMax}	Nm	5900															
工作效率 Work efficiency	η	%	97							94								
工作寿命 ⁽³⁾ Service life	L_h	h	20000															
噪音 ($i=10$ 和 $n_1=3000rpm$, 空载) Noise ($i=10$ and $n_1=3000rpm$, no load)	L_{PA}	DB(A)	≤ 70															
重量 Weight	m	Kg	48							62								
安装方向 Installation direction			任意方向/Any direction															
使用温度 ⁽⁴⁾ Operating temperature	°C		-10~90															
润滑方式 Lubrication method			终生润滑/Lifetime lubrication															
防护等级 Protection level			IP65															
转动惯量 Moment of inertia 按减速机输入直径(mm) Input diameter based on the reducer(mm)	42	J_1	Kgcm ²	70	68	65	55	52	45	40	16	15.5	14	14	13	12	10.8	9.5
	55	J_1	Kgcm ²	95	77	75	68	65	60	55	28	27	26.5	25.5	24	23	21	19.5

1. 可选其他减速比
2. 输出轴中心点
3. 连续运转时, 使用寿命为10000h
4. 对温度有特殊要求请联系

1. Optional other ratio
2. Output shaft center point
3. Service life of 10000h in continuous operation
4. For special requirements on temperature, please contact

减速机性能资料 REDUCER PERFORMANCE DATA

单级/One-stage

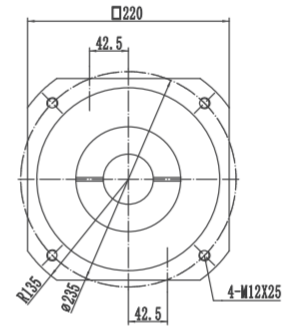
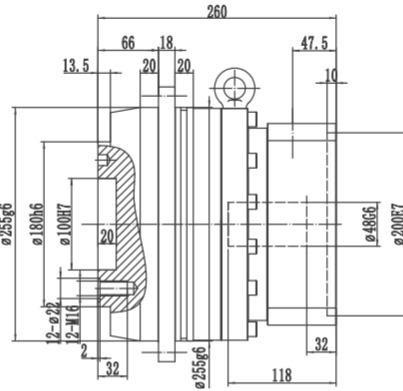
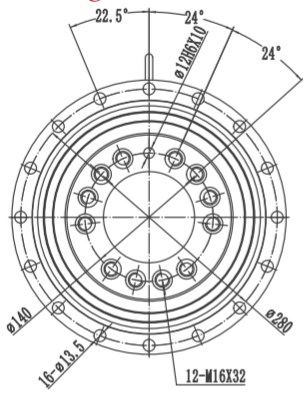

A ≤ 48

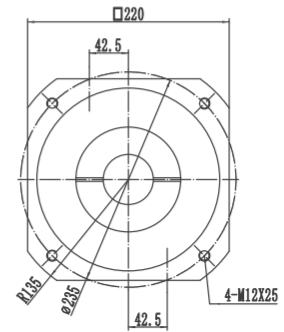
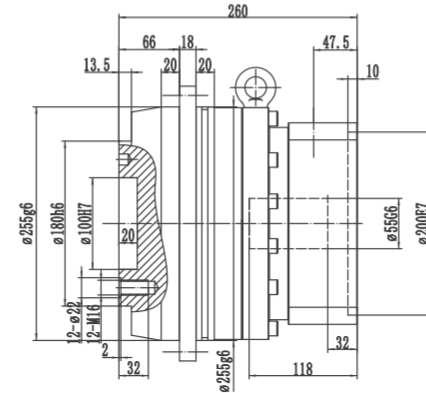
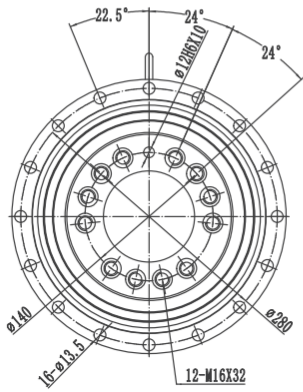

B ≤ 55

双级/Two-stage

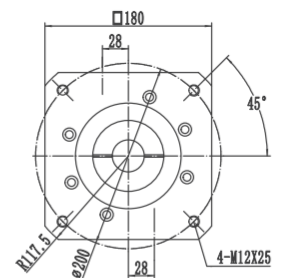
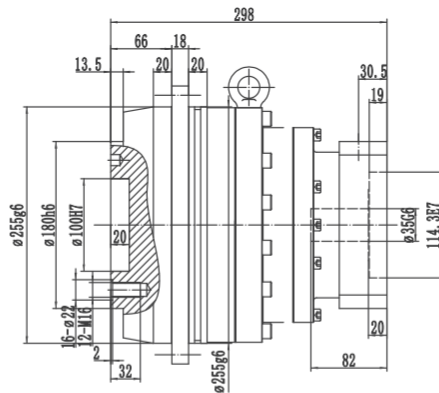
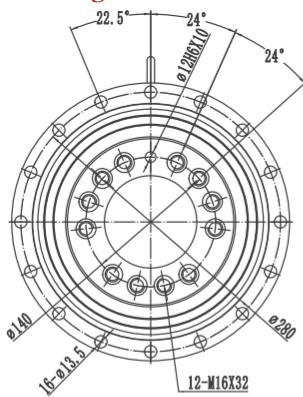

C ≤ 35

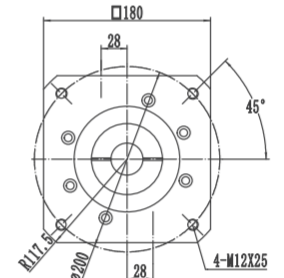
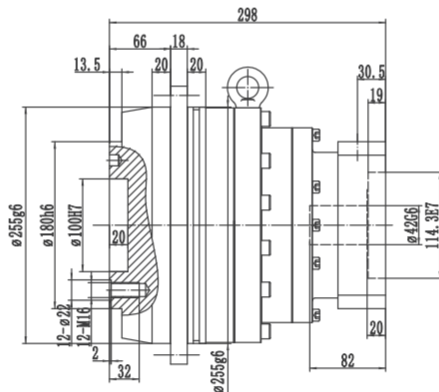
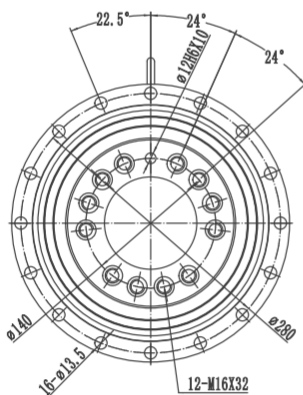

D ≤ 42

- (1) 请参照马达轴径尺寸
 - (2) 马达轴最长长度, 如有特殊的马达轴尺寸, 请联络
 - (3) 减速机输入端尺寸, 依马达的法兰面而定
- *如无适合的尺寸, 请联系

- (1) Please refer to the motor shaft diameter
 - (2) Motor shaft length, for special motor shaft size, please contact
 - (3) Reducer input size, depending on the flange surface of the motor
- *If no suitable size available, please contact